

Dingli Scissor Lifts Product Manuals

Engine Oil-free Electric



ZHEJIANG DINGLI MACHINERY CO., LTD.

ADD:188 Qihang Road, Leidian Town, Deqing, Zhejiang, P.R.C
P.C:313219
Tel:+86-572-8681688
E-Mail:export@cndingli.com
Https://www.cndingli.com

As the technology is constantly updated, technical parameters are subject to change without notice. This manual is for reference only.
The copyright is owned by Zhejiang Dingli. No content may be copied or plagiarize for any purpose without written permission.
April 2024 edition

DINGLI[®]
Exceed · New Height



Founded in 2005, [Zhejiang Dingli Machinery Co., Ltd.](#) is a leading manufacturer of intelligent aerial work platforms in the world, covering a total area of 710,000 square meters (175.4 acres), with a construction area of 590,000 square meters and an annual output value of more than 10 billion.

Dingli has been applying the core concepts of "Carbon Peak" and "Carbon Neutral", as well as energy saving and emission reduction throughout the whole process of corporate governance, which are mainly reflected in the green travel of employees, green park construction, green production and manufacturing, green product R&D, and green recycling re-manufacturing

Technological innovation is the core tenet of the company, Dingli has R&D centers in Italy, Germany and the USA, an Enterprise Research Institute in China, has been awarded more than 250 patents, of which more than 100 patents of invention, more than 60 foreign patents, 5 computer software copyright registration certificate, Dingli also participated in the formulation of 16 national standards and 9 industry standards, fully realizing technological globalization. Dingli's over 200 types of aerial work platforms by independent R&D that are the most in the industry, have all passed authoritative certifications such as CE in Europe and ANSI in the US, and are exported to over 80 countries and regions worldwide.

In line with the trend of electrification, greening and intelligence, Dingli has realized collaborative, green and safe manufacturing based on the "future factory" with the highest degree of automation in the industry. Electrification is the key for Dingli's energy-saving solutions to customers. Dingli is the first in the industry to electrify the entire range of products, among which the boom series with large load capacity and modular design is the first in the industry. By advocating the efficient use of recycling energy, the company has established re-manufacturing factories to provide customers with full life cycle services for products.

In order to better convey the global green development concept, Dingli has invested in MAGNI (Italy), CMEC (USA) and TEUPEN (Germany).

with innovative technology as the grip, green products as the entry point, Dingli set up more than ten overseas subsidiaries, serving global customers with electric aerial work platforms.

Dingli has been recognized as a "National Manufacturing Single Item Champion Demonstration Enterprise" by the Ministry of Industry and Information Technology; been awarded the "IAPA 2024 Product of the Year Categories - Scissor Lifts & Vertical Masts", realizing the zero breakthrough of Chinese manufacturing in the industry's most authoritative international awards. Dingli has been honored with "2021 ACCESS M20 Global Aerial Work Platform Top 3 Manufacturers", "Top 40 Global Construction Machinery Manufacturers". Mr. Xu Shugen, president of the board, was the first Chinese selected as a member of the IAPA judging panel since the establishment of this international award.

Dingli is also committed to building an equal, diverse and inclusive corporate environment, by actively empowering women to realize gender diversity in all positions in the male-dominated machinery manufacturing industry, respecting different voices to keep team innovative and resilient for a long time, promoting the development of the industry and ushering in a new era of electrification of non-road mobile machinery to lead the green transformation. Meanwhile, Dingli has built a harmonious supply chain, connected upstream and downstream to create the world's only industrial park for aerial work platforms. Dingli has been fulfilling social responsibilities establish the "HongDing Fund", and actively carry out warm-hearted volunteer service activities such as poverty relief, fundraising and disaster relief, etc.

Through the entire life cycle of enterprise ecology, "green sustainability" is becoming the focus of Dingli's high-quality development. In the future, the company will continue to upgrade the "future factories", deepen the green and energy-saving strategy, lead the "new era of electrification of non-road mobile machinery", make aerial work platforms "Made in China" shine internationally.

Scissor Lifts

Dingli's scissor series has the most complete working height coverage and the largest range of specifications in the industry, including two categories: electric powered and diesel powered, which are divided into large scissors, compact scissors, mini scissors, etc. The maximum working height of the series covers 6-32m, and the maximum load is 1000kg.

Large Scissor Series

The electric and diesel models are included, offering maximum working height of 12-32m and maximum load of 1000kg, with the advantages of high working height, large load, large platform, strong power, etc. In addition to all the advantages of the diesel rough-terrain scissors, the electric rough-terrain scissors also feature the environmental advantages such as no noise and zero emission.

Compact Scissor Series

AC scissor series and oil-free & all-electric series are included, offering maximum working height of 8-16m and maximum load of 540kg. The AC scissors are equipped with a fully sealed AC system (for driving and lifting) to replace the traditional DC system (for driving and lifting), offering the advantages of maintenance-free, more waterproof, more efficient, and safer. Oil-free & all-electric scissors use electric actuator instead of traditional hydraulic cylinders, making the whole machine eliminate hydraulic oil, which has the features of more environmentally friendly, high energy saving and maintenance-free.

Mini Scissor Series

The maximum working height of the series covers 6-8m, the maximum load is 240kg. The machines in the series are small in size and flexible, light in weight, with advantages like no noise, no pollution, free to enter and exit the elevators at will, they are specially designed for working at height in building mezzanine.

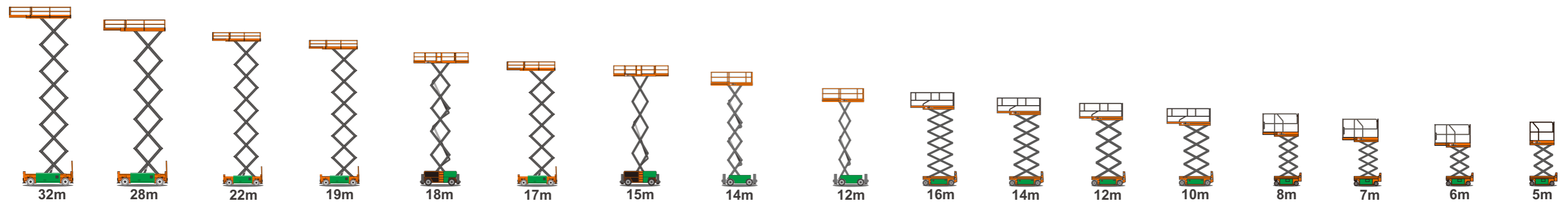
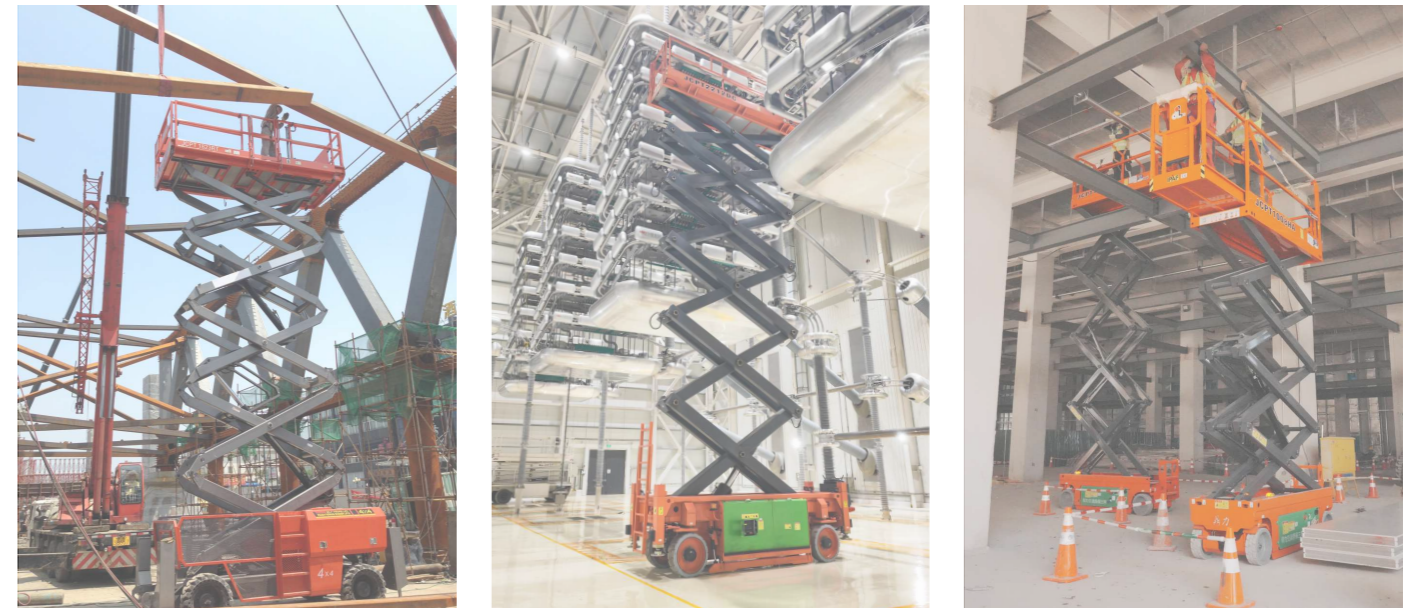

JCPT3225RT	JCPT2825RT	JCPT2223RTB	JCPT1923RTB	JCPT1823RTB	JCPT1712DCL	JCPT1523RTB	JCPT1418RT	JCPT1218RT	JCPT1614AC	JCPT1412AC	JCPT1212AC	JCPT1012AC	JCPT0812AC	JCPT0708DCM	JCPT0608DCM	JCPT0507PA
JCPT3225DC	JCPT2825DC	JCPT2223DC	JCPT1923DC	JCPT1823DCB		JCPT1523DCB	JCPT1418DC	JCPT1218DC	JCPT1614HA	JCPT1412HA	JCPT1212HA	JCPT1012HA	JCPT0812HA	JCPT0708DCH	JCPT0608DCH	
JCPT3214DC	JCPT2814DC	JCPT2216DC	JCPT1923RTL	JCPT1823RTL		JCPT1523RTL			JCPT1614AC+	JCPT1412AC+	JCPT1212AC+	JCPT1012AC+	JCPT0808AC	JCPT0708PA	JCPT0607DCM	
		JCPT2212DC	JCPT1923DCL	JCPT1823DCL		JCPT1523DCL			JCPT1614PA	JCPT1412PA	JCPT1212PA	JCPT1012PA	JCPT0808HA	JCPT0708PAH	JCPT0607DCH	
			JCPT1912DC						JCPT1612AC			JCPT1008AC	JCPT0808AC+	JCPT0707DCM	JCPT0607PA	
			JCPT1912DCL						JCPT1612HA			JCPT1008HA	JCPT0808PA		JCPT0607PAH	
									JCPT1612AC+			JCPT1008AC+	JCPT0807AC		JCPT0607B	
									JCPT1612ACS			JCPT1008ACS	JCPT0807HA			
									JCPT1612HAS			JCPT1008PA	JCPT0807AC+			
									JCPT1612PA				JCPT0807PA			

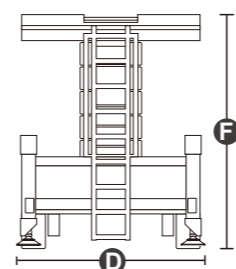
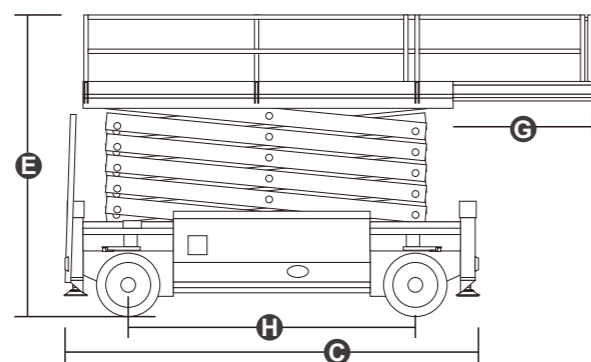
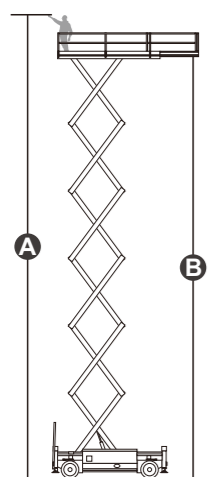

Model	JCPT3225RT	JCPT3225DC	JCPT3214DC
Dimension			
Max. Working Height (Indoor) CE,ANSI92.20 A	32.00m 105ft	32.00m 105ft	32.00m 105ft
Max. Working Height (Outdoor) ANSI92.20 B	32.00m 105ft	32.00m 105ft	32.00m 105ft
Max. Platform Height (Indoor) CE,ANSI92.20	30.00m 98ft 5in	30.00m 98ft 5in	30.00m 98ft 5in
Max. Platform Height (Outdoor) ANSI92.20	30.00m 98ft 5in	30.00m 98ft 5in	30.00m 98ft 5in
Overall Length C	6.73m 22ft 1in	6.73m 22ft 1in	6.41m 21ft
Overall Width D	2.55m 8ft 4in	2.55m 8ft 4in	1.40m 4ft 7in
Overall Height(Rails Up) E	4.13m 13ft 7in	4.13m 13ft 7in	4.16m 13ft 8in
Overall Height(Rails Down) F	3.19m 10ft 6in	3.19m 10ft 6in	3.17m 10ft 5in
Platform Size(L×W)	6.20m×2.45m 20ft 4in×8ft	6.20m×2.45m 20ft 4in×8ft	5.85m×1.20m 19ft 2in×3ft 11in
Platform Extension Size G	2.10m 6ft 11in	2.10m 6ft 11in	1.90m 6ft 3in
Ground Clearance(Stowed/Raised)	0.20m 8in	0.20m 8in	0.19m/0.02m 8in/1in
Wheelbase H	4.86m 15ft 11in	4.86m 15ft 11in	4.87m 16ft
Turning Radius(Inside/Outside)	3.80m/6.30m 12ft 6in/20ft 8in	3.80m/6.30m 12ft 6in/20ft 8in	2.60m/3.50m 8ft 6in/11ft 6in
Tyres	15-625	15-625	28×12-22
Performance			
S.W.L	1000kg 2204lb	1000kg 2204lb	750kg 1653lb
S.W.L On Extension	1000kg 2204lb	1000kg 2204lb	750kg 1653lb
Max. Occupants (Indoor/Outdoor) CE	4/4	4/4	2/2
Max. Occupants (Indoor/Outdoor) ANSI92.20	4/4	4/4	2/2
Gradeability	40%	30%	30%
Travel Speed(Stowed)	4.0km/h 2.49mph	3.5km/h 2.17mph	1.5km/h 0.93mph
Travel Speed(Raised)	0.3km/h 0.19mph	0.3km/h 0.19mph	0.1km/h 0.06mph
Max. Working Slope	2°/3°	2°/3°	1°(0°)
Up/Down Speed	150/120sec	160/120sec	160/105sec
Weight			
Overall Weight	23950kg 52800lb	23950kg 52800lb	22200kg 48942lb
Power			
Diesel Engine	55kW/2600rpm	/	/
Diesel Tank	130L 34gal	/	/
Hydraulic Tank	260L 69gal	260L 69gal	220L 58gal
Battery(Lead-acid Battery)	/	80V/520Ah	80V/520Ah
Charger	/	80V/80A	80V/80A
Driving Motor	/	4×56VAC/6kW	4×53VAC/2kW
Lifting Motor	/	53VAC/28kW	53VAC/28kW

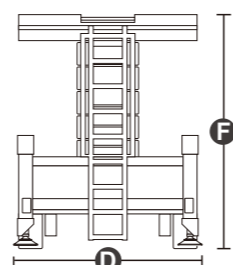
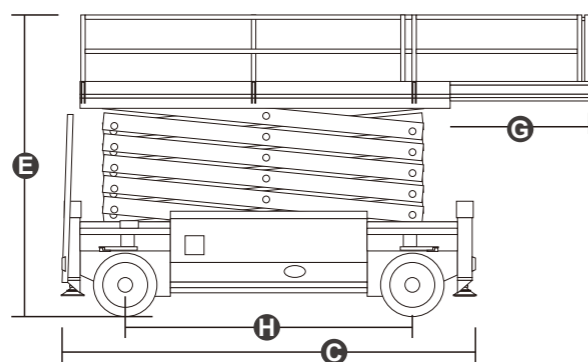
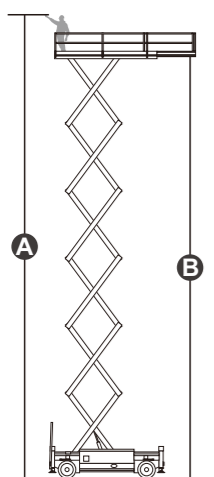

Model	JCPT2825RT	JCPT2825DC	JCPT2814DC
Dimension			
Max. Working Height (Indoor) CE,ANSI92.20 A	28.00m 91ft 10in	28.00m 91ft 10in	28.00m 91ft 10in
Max. Working Height (Outdoor) ANSI92.20 B	28.00m 91ft 10in	28.00m 91ft 10in	28.00m 91ft 10in
Max. Platform Height (Indoor) CE,ANSI92.20	26.00m 85ft 4in	26.00m 85ft 4in	26.00m 85ft 4in
Max. Platform Height (Outdoor) ANSI92.20	26.00m 85ft 4in	26.00m 85ft 4in	26.00m 85ft 4in
Overall Length C	5.96m 19ft 7in	5.96m 19ft 7in	5.69m 18ft 8in
Overall Width D	2.50m 8ft 2in	2.50m 8ft 2in	1.40m 4ft 7in
Overall Height(Rails Up) E	4.13m 13ft 7in	4.13m 13ft 7in	4.16m 13ft 8in
Overall Height(Rails Down) F	3.19m 10ft 6in	3.19m 10ft 6in	3.17m 10ft 5in
Platform Size(L×W)	5.48m×2.45m 18ft×8ft	5.48m×2.45m 18ft×8ft	5.08m×1.20m 19ft 2in × 3ft 11in
Platform Extension Size G	2.10m 6ft 11in	2.10m 6ft 11in	1.90m 6ft 3in
Ground Clearance(Stowed/Raised)	0.23m 9in	0.23m 9in	0.19m/0.02m 7in/1in
Wheelbase H	4.10m 13ft 5in	4.10m 13ft 5in	4.14m 13ft 7in
Turning Radius(Inside/Outside)	3.50m/6.00m 11ft 6in/19ft 8in	3.50m/6.00m 11ft 6in/19ft 8in	2.50m/3.30m 8ft 2in/10ft 10in
Tyres	355/55D625	355/55D625	28×12-22
Performance			
S.W.L	1000kg 2204lb	1000kg 2204lb	750kg 1653lb
S.W.L On Extension	1000kg 2204lb	1000kg 2204lb	750kg 1653lb
Max. Occupants (Indoor/Outdoor) CE	4/4	4/4	2/2
Max. Occupants (Indoor/Outdoor) ANSI92.20	4/4	4/4	2/2
Gradeability	40%	30%	30%
Travel Speed(Stowed)	4.0km/h 2.49mph	3.5km/h 2.17mph	1.5km/h 0.93mph
Travel Speed(Raised)	0.3km/h 0.19mph	0.3km/h 0.19mph	0.1km/h 0.06mph
Max. Working Slope	2°/3°	2°/3°	1°(0°)
Up/Down Speed	110/100sec	130/100sec	115/95sec
Weight			
Overall Weight	19800kg 43651lb	19750kg 43541lb	18260kg 40256lb
Power			
Diesel Engine	55kW/2600rpm	/	/
Diesel Tank	130L 34gal	/	/
Hydraulic Tank	260L 69gal	260L 69gal	180L 47gal
Battery(Lead-acid Battery)	/	80V/520Ah	80V/520Ah
Charger	/	80V/80A	80V/80A
Driving Motor	/	4×53VAC/2kW	4×53VAC/2kW
Lifting Motor	/	53VAC/28kW	53VAC/28kW

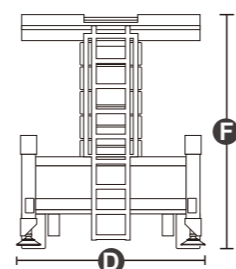
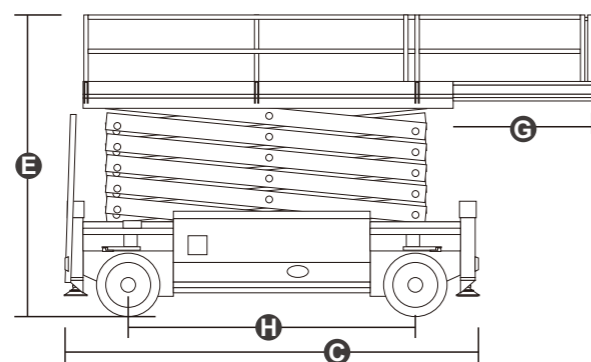
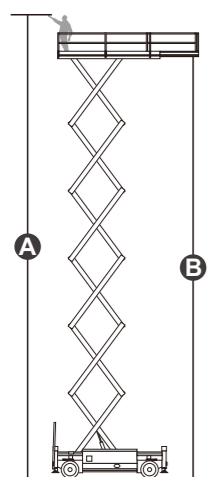

Model	JCPT2223RTB	JCPT2223DC	JCPT2216DC	JCPT2212DC
Dimension				
Max. Working Height (Indoor) CE,ANSI92.20 A	22.00m 72ft 2in	22.00m 72ft 2in	22.00m 72ft 2in	22.00m 72ft 2in
Max. Working Height (Outdoor) ANSI92.20 B	22.00m 72ft 2in	22.00m 72ft 2in	22.00m 72ft 2in	22.00m 72ft 2in
Max. Platform Height (Indoor) CE,ANSI92.20	20.00m 65ft 7in	20.00m 65ft 7in	20.00m 65ft 7in	20.00m 65ft 7in
Max. Platform Height (Outdoor) ANSI92.20	20.00m 65ft 7in	20.00m 65ft 7in	20.00m 65ft 7in	20.00m 65ft 7in
Overall Length C	4.95m 16ft 3in	4.95m 16ft 3in	4.72m 15ft 6in	4.72m 15ft 6in
Overall Width D	2.46m 8ft 1in	2.46m 8ft 1in	1.60m 5ft 3in	1.25m 4ft 1in
Overall Height(Rails Up) E	3.86m 12ft 8in	3.86m 12ft 8in	3.82m 12ft 6in	3.82m 12ft 6in
Overall Height(Rails Down) F	3.00m 9ft 10in	3.00m 9ft 10in	2.99m 9ft 10in	2.99m 9ft 10in
Platform Size(L×W)	4.59m×2.25m 15ft 1in × 7ft 5in	4.59m×2.25m 15ft 1in × 7ft 5in	4.30m×1.54m 14ft 1in × 5ft	4.30m×1.19m 14ft 1in × 3ft 11in
Platform Extension Size G	2.70m 8ft 10in	2.70m 8ft 10in	1.80m 5ft 11in	1.80m 5ft 11in
Ground Clearance(Stowed/Raised)	0.40m 1ft 4in	0.40m 1ft 4in	0.20m/0.02m 8in/1in	0.20m/0.02m 8in/1in
Wheelbase H	3.30m 10ft 10in	3.30m 10ft 10in	3.18m 10ft 5in	3.18m 10ft 5in
Turning Radius(Inside/Outside)	1.25m/3.40m 4ft 1in/11ft 2in	1.25m/3.40m 4ft 1in/11ft 2in	2.30m/3.00m 7ft 6in/9ft 10in	1.60m/2.30m 5ft 3in/7ft 7in
Tyres	36×14-20	36×14-20	28×10-22	28×10-22
Performance				
S.W.L	750kg 1653lb	750kg 1653lb	750kg 1653lb	750kg 1653lb
S.W.L On Extension	750kg 1653lb	750kg 1653lb	750kg 1653lb	750kg 1653lb
Max. Occupants (Indoor/Outdoor) CE	4/4	4/4	2/2	2/2
Max. Occupants (Indoor/Outdoor) ANSI92.20	4/4	4/4	2/2	2/2
Gradeability	40%	30%	25%	25%
Travel Speed(Stowed)	4.7km/h 2.92mph	5.0km/h 3.10mph	3.5km/h 2.17mph	3.5km/h 2.17mph
Travel Speed(Raised)	0.4km/h 0.25mph	0.4km/h 0.25mph	0.5km/h 0.31mph	0.5km/h 0.31mph
Max. Working Slope	2°/3°	2°/3°	1°(0°)	1°(0°)
Up/Down Speed	75/75sec	90/75sec	85/75sec	85/75sec
Weight				
Overall Weight	13000kg 28660lb	13400kg 29541lb	13000kg 28660lb	12350kg 27227lb
Power				
Diesel Engine	36.4kW/2600rpm	/	/	/
Diesel Tank	100L 26gal	/	/	/
Hydraulic Tank	150L 40gal	150L 40gal	130L 34gal	130L 34gal
Battery(Lead-acid Battery)	/	48V/630Ah	48V/630Ah	48V/630Ah
Charger	/	48V/60A	48V/60A	48V/60A
Driving Motor	/	4×32VAC/3.3kW	4×32VAC/3.3kW	4×32VAC/3.3kW
Lifting Motor	/	2×48VDC/10.0kW	2×48VDC/8.0kW	2×48VDC/8.0kW

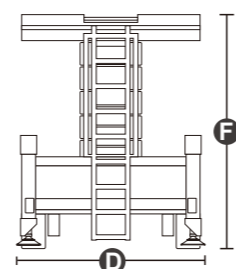
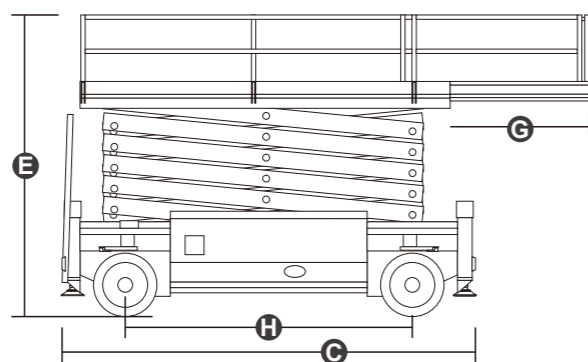
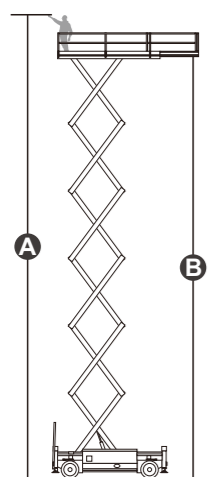

Model	JCPT1923RTB	JCPT1923DC	JCPT1923RTL	JCPT1923DCL
Dimension				
Max. Working Height (Indoor) CE,ANSI92.20 A	19.00m 62ft 4in	19.00m 62ft 4in	19.00m 62ft 4in	19.00m 62ft 4in
Max. Working Height (Outdoor) ANSI92.20 B	19.00m 62ft 4in	19.00m 62ft 4in	19.00m 62ft 4in	19.00m 62ft 4in
Max. Platform Height (Indoor) CE,ANSI92.20	17.00m 55ft 9in	17.00m 55ft 9in	17.00m 55ft 9in	17.00m 55ft 9in
Max. Platform Height (Outdoor) ANSI92.20	17.00m 55ft 9in	17.00m 55ft 9in	17.00m 55ft 9in	17.00m 55ft 9in
Overall Length C	4.95m 16ft 3in	4.95m 16ft 3in	4.46m 14ft 8in	4.46m 14ft 8in
Overall Width D	2.46m 8ft 1in	2.46m 8ft 1in	2.29m 7ft 6in	2.29m 7ft 6in
Overall Height(Rails Up) E	3.61m 11ft 10in	3.61m 11ft 10in	3.60m 11ft 10in	3.60m 11ft 10in
Overall Height(Rails Down) F	2.75m 9ft	2.75m 9ft	2.75m 9ft	2.75m 9ft
Platform Size(L×W)	4.59m×2.25m 15ft × 7ft 5in	4.59m×2.25m 15ft × 7ft 5in	4.06m×2.00m 13ft 4in×6ft 7in	4.06m×2.00m 13ft 4in×6ft 7in
Platform Extension Size G	2.70m 8ft 10in	2.70m 8ft 10in	2.00m 6ft 7in	2.00m 6ft 7in
Ground Clearance(Stowed/Raised)	0.40m 1ft 4in	0.40m 1ft 4in	0.40m 1ft 4in	0.40m 1ft 4in
Wheelbase H	3.30m 10ft 10in	3.30m 10ft 10in	2.85m 9ft 4in	2.85m 9ft 4in
Turning Radius(Inside/Outside)	1.25m/3.40m 4ft 1in/11ft 2in	1.25m/3.40m 4ft 1in/11ft 2in	1.00m/3.20m 3ft 3in/10ft 6in	1.00m/3.20m 3ft 3in/10ft 6in
Tyres	36×14-20	36×14-20	33×12-20	33×12-20
Performance				
S.W.L	750kg 1653lb	750kg 1653lb	680kg 1499lb	680kg 1499lb
S.W.L On Extension	750kg 1653lb	750kg 1653lb	680kg 1499lb	680kg 1499lb
Max. Occupants (Indoor/Outdoor) CE	4/4	4/4	4/4	4/4
Max. Occupants (Indoor/Outdoor) ANSI92.20	4/4	4/4	4/4	4/4
Gradeability	40%	30%	40%	40%
Travel Speed(Stowed)	4.7km/h 2.92mph	5.0km/h 3.10mph	4.5km/h 2.80mph	4.5km/h 2.80mph
Travel Speed(Raised)	0.4km/h 0.25mph	0.4km/h 0.25mph	0.6km/h 0.37mph	0.6km/h 0.37mph
Max. Working Slope	2°/3°	2°/3°	2°/3°	2°/3°
Up/Down Speed	68/70sec	80/70sec	70/70sec	70/70sec
Weight				
Overall Weight	12400kg 27337lb	13030kg 28726lb	10530kg 23214lb	10870kg 23964lb
Power				
Diesel Engine	36.4kW/2600rpm	/	36.4kW/2600rpm	/
Diesel Tank	100L 26gal	/	100L 26gal	/
Hydraulic Tank	150L 39gal	150L 39gal	135L 35gal	135L 35gal
Battery(Lead-acid Battery)	/	48V/630Ah	/	48V/450Ah
Charger	/	48V/60A	/	48V/60A
Driving Motor	/	4×32VAC/3.3kW	/	4×32VAC/3.3kW
Lifting Motor	/	2×48VDC/10.0kW	/	2×48VDC/8.0kW



Model	JCPT1912DC	JCPT1912DCL
Dimension		
Max. Working Height (Indoor) CE,ANSI92.20 A	19.00m 62ft 4in	19.00m 62ft 4in
Max. Working Height (Outdoor) ANSI92.20 B	19.00m 62ft 4in	19.00m 62ft 4in
Max. Platform Height (Indoor) CE,ANSI92.20	17.00m 55ft 9in	17.00m 55ft 9in
Max. Platform Height (Outdoor) ANSI92.20	17.00m 55ft 9in	17.00m 55ft 9in
Overall Length C	4.72m 15ft 6in	3.76m 12ft 4in
Overall Width D	1.25m 4ft 1in	1.25m 4ft 1in
Overall Height(Rails Up) E	3.57m 11ft 8in	3.24m 10ft 8in
Overall Height(Rails Down) F	2.74m 9ft	2.47m 8ft 1in
Platform Size(L×W)	4.30m×1.19m 14ft 1in × 3ft 11in	3.44m×1.17m 11ft 3in × 3ft 10in
Platform Extension Size G	1.80m 5ft 11in	1.20m 3ft 11in
Ground Clearance(Stowed/Raised)	0.20m/0.02m 8in/1in	0.15m/0.025m 6in/1in
Wheelbase H	3.18m 10ft 5in	2.89m 9ft 6in
Turning Radius(Inside/Outside)	1.60m/2.30m 5ft 3in/7ft 6in	1.00m/3.50m 3ft 3in/11ft 6in
Tyres	28×10-22	22×9×16
Performance		
S.W.L	750kg 1653lb	500kg 1102lb
S.W.L On Extension	750kg 1653lb	500kg 1102lb
Max. Occupants (Indoor/Outdoor) CE	2/2	2/0
Max. Occupants (Indoor/Outdoor) ANSI92.20	2/2	2/0
Gradeability	25%	30%
Travel Speed(Stowed)	3.5km/h 2.17mph	4.5km/h 2.80mph
Travel Speed(Raised)	0.5km/h 0.31mph	0.4km/h 0.25mph
Max. Working Slope	1°(0°)	1.5°/3°
Up/Down Speed	75/72sec	70/76sec
Weight		
Overall Weight	11750kg 25904lb	7140kg 15741lb
Power		
Diesel Engine	/	/
Diesel Tank	/	/
Hydraulic Tank	130L 34gal	50L 13.2gal
Battery(Lead-acid Battery)	48V/630Ah	48V/360Ah
Charger	48V/60A	48V/60A
Driving Motor	4×32VAC/3.3kW	2×32VAC/3.3kW
Lifting Motor	2×48VDC/8.0kW	48VDC/12.0kW

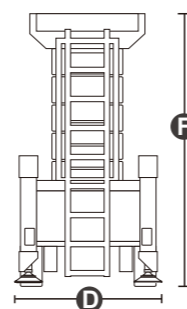
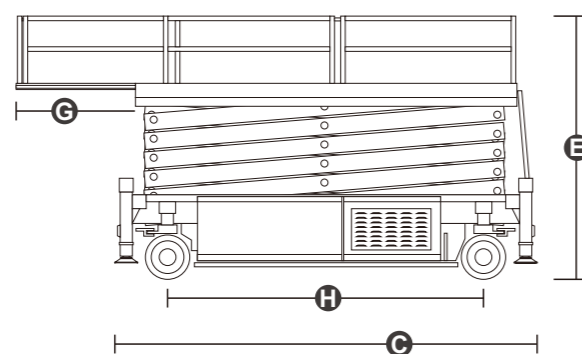
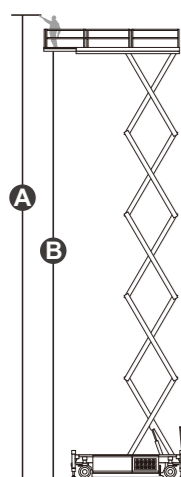

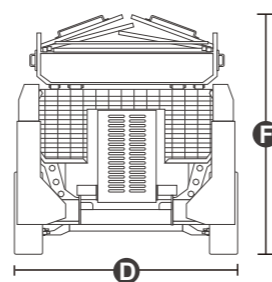
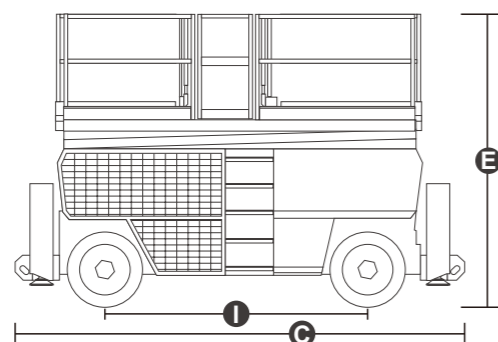
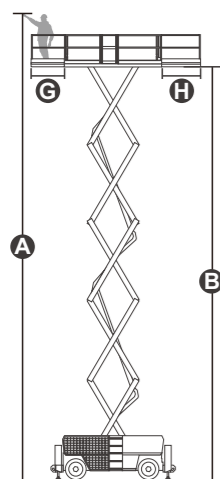

Model	JCPT1823RTB	JCPT1823DCB	JCPT1823RTL	JCPT1823DCL
Dimension				
Max. Working Height (Indoor) CE,ANSI92.20 A	18.00m 59ft 1in	18.00m 59ft 1in	18.00m 59ft 1in	18.00m 59ft 1in
Max. Working Height (Outdoor) ANSI92.20 B	18.00m 59ft 1in	18.00m 59ft 1in	18.00m 59ft 1in	18.00m 59ft 1in
Max. Platform Height (Indoor) CE,ANSI92.20	16.00m 52ft 6in	16.00m 52ft 6in	16.00m 52ft 6in	16.00m 52ft 6in
Max. Platform Height (Outdoor) ANSI92.20	16.00m 52ft 6in	16.00m 52ft 6in	16.00m 52ft 6in	16.00m 52ft 6in
Overall Length C	4.88m 16ft	4.88m 16ft	4.88m 16ft	4.88m 16ft
Overall Width D	2.27m 7ft 5in	2.29m 7ft 6in	2.33m 7ft 8in	2.33m 7ft 8in
Overall Height(Rails Up) E	3.19m 10ft 6in	3.19m 10ft 6in	3.23m 10ft 7in	3.23m 10ft 7in
Overall Height(Rails Down) F	2.49m 8ft 2in	2.49m 8ft 2in	2.47m 8ft 1in	2.47m 8ft 1in
Platform Size(L×W)	3.98m×1.83m 13ft 1in ×6ft	3.98m×1.83m 13ft 1in ×6ft	3.98m×1.83m 13ft 1in ×6ft	3.98m×1.83m 13ft 1in ×6ft
Platform Extension Size G/H	1.43m/1.16m 4ft 8in/3ft 10in	1.43m/1.16m 4ft 8in/3ft 10in	1.43m/1.16m 4ft 8in/3ft 10in	1.43m/1.16m 4ft 8in/3ft 10in
Ground Clearance(Stowed/Raised)	0.30m 1ft	0.30m 1ft	0.30m 1ft	0.30m 1ft
Wheelbase I	2.86m 9ft 5in	2.86m 9ft 5in	2.86m 9ft 5in	2.86m 9ft 5in
Turning Radius(Inside/Outside)	2.35m/5.20m 7ft 9in/17ft 1in	2.35m/5.20m 7ft 9in/17ft 1in	2.70m/5.50m 8ft 10in/18ft	2.70m/5.50m 8ft 10in/18ft
Tyres	33×12-20	33×12-20	315/55/D20	315/55/D20
Performance				
S.W.L	680kg 1499lb	680kg 1499lb	680kg 1499lb	680kg 1499lb
S.W.L On Extension	227kg 500lb	227kg 500lb	227kg 500lb	227kg 500lb
Max. Occupants (Indoor/Outdoor) CE	4/4	4/4	4/4	4/4
Max. Occupants (Indoor/Outdoor) ANSI92.20	4/4	4/4	4/4	4/4
Gradeability	40%	40%	30%	40%
Travel Speed(Stowed)	6.0km/h 3.73mph	6.0km/h 3.73mph	5.0km/h 3.11mph	5.5km/h 3.41mph
Travel Speed(Raised)	1.1km/h 0.68mph	1.0km/h 0.62mph	1.0km/h 0.62mph	1.0km/h 0.62mph
Max. Working Slope	2°/3°	2°/3°	2°/3°	2°/3°
Up/Down Speed	75/74sec	80/70sec	78/74sec	80/74sec
Weight				
Overall Weight	8590kg 18937lb	8900kg 19621lb	8560kg 18872lb	9210kg 20304lb
Power				
Diesel Engine	36.8kW/2700rpm	/	18.2kW/3000rpm	/
Diesel Tank	100L 26gal	/	100L 26gal	/
Hydraulic Tank	130L 34gal	130L 34gal	120L 32gal	120L 32gal
Battery(Lead-acid Battery)	/	48V/450Ah	/	48V/450Ah
Charger	/	48V/60A	/	48V/60A
Driving Motor	/	4×32VAC/3.3kW	/	32VAC/9kW
Lifting Motor	/	2×48VDC/8.0kW	/	32VAC/15kW

Electric

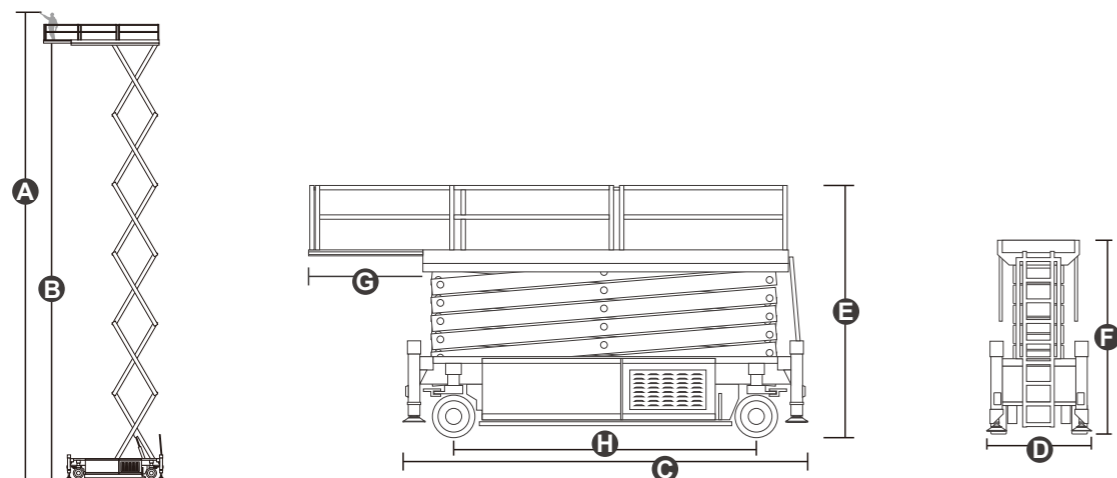

Model		JCPT1712DCL
Dimension		
Max. Working Height (Indoor) CE,ANSI92.20 A		17.20m 56ft 5in
Max. Working Height (Outdoor) ANSI92.20 B		17.20m 56ft 5in
Max. Platform Height (Indoor) CE,ANSI92.20		15.20m 49ft 10in
Max. Platform Height (Outdoor) ANSI92.20		15.20m 49ft 10in
Overall Length C		3.36m 11ft
Overall Width D		1.25m 4ft 1in
Overall Height(Rails Up) E		3.24m 10ft 8in
Overall Height(Rails Down) F		2.47m 8ft 1in
Platform Size(L×W)		3.04m×1.17m 10ft × 3ft 10in
Platform Extension Size G		1.20m 3ft 11in
Ground Clearance(Stowed/Raised)		0.15m/0.025m 6in/1in
Wheelbase H		2.49m 8ft 2in
Turning Radius(Inside/Outside)		0.60m/3.00m 2ft/9ft 10in
Tyres		22×9×16
Performance		
S.W.L		500kg 1102lb
S.W.L On Extension		500kg 1102lb
Max. Occupants (Indoor/Outdoor) CE		2/0
Max. Occupants (Indoor/Outdoor) ANSI92.20		2/0
Gradeability		30%
Travel Speed(Stowed)		4.5km/h 2.80mph
Travel Speed(Raised)		0.4km/h 0.25mph
Max. Working Slope		1.5°/3°
Up/Down Speed		65/68sec
Weight		
Overall Weight		6280kg 13845lb
Power		
Hydraulic Tank		45L 11.7gal
Battery(Lead-acid Battery)		48V/320Ah
Charger		48V/60A
Driving Motor		2×32VAC/3.3kW
Lifting Motor		48VDC/10.0kW

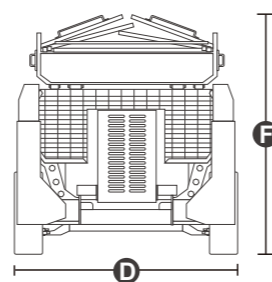
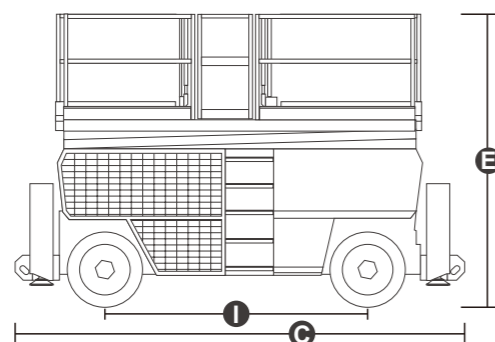
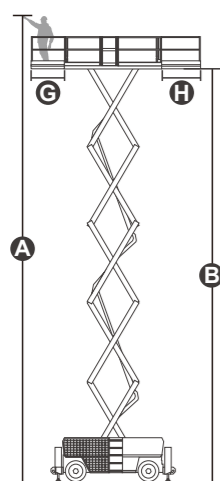

Model	JCPT1523RTB	JCPT1523DCB	JCPT1523RTL	JCPT1523DCL
Dimension				
Max. Working Height (Indoor) CE,ANSI92.20 A	15.00m 49ft 3in	15.00m 49ft 3in	15.00m 49ft 3in	15.00m 49ft 3in
Max. Working Height (Outdoor) ANSI92.20 B	15.00m 49ft 3in	15.00m 49ft 3in	15.00m 49ft 3in	15.00m 49ft 3in
Max. Platform Height (Indoor) CE,ANSI92.20	13.00m 42ft 8in	13.00m 42ft 8in	13.00m 42ft 8in	13.00m 42ft 8in
Max. Platform Height (Outdoor) ANSI92.20	13.00m 42ft 8in	13.00m 42ft 8in	13.00m 42ft 8in	13.00m 42ft 8in
Overall Length(Without Outriggers)	3.98m 13ft 1in	3.98m 13ft 1in	3.98m 13ft 1in	3.98m 13ft 1in
Overall Length(With Outriggers) C	4.88m 16ft	4.88m 16ft	4.88m 16ft	4.88m 16ft
Overall Width D	2.27m 7ft 5in	2.29m 7ft 6in	2.33m 7ft 8in	2.33m 7ft 8in
Overall Height(Rails Up) E	2.98m 9ft 9in	2.98m 9ft 9in	3.02m 9ft 11in	3.02m 9ft 11in
Overall Height(Rails Down) F	2.28m 7ft 6in	2.26m 7ft 6in	2.26m 7ft 5in	2.26m 7ft 5in
Platform Size(L×W)	3.98m×1.83m 13ft 1in ×6ft	3.98m×1.83m 13ft 1in ×6ft	3.98m×1.83m 13ft 1in ×6ft	3.98m×1.83m 13ft 1in ×6ft
Platform Extension Size G/H	1.43m/1.16m 4ft 8in/3ft 10in	1.43m/1.16m 4ft 8in/3ft 10in	1.43m/1.16m 4ft 8in/3ft 10in	1.43m/1.16m 4ft 8in/3ft 10in
Ground Clearance(Stowed/Raised)	0.30m 1ft	0.30m 1ft	0.30m 1ft	0.30m 1ft
Wheelbase I	2.86m 9ft 5in	2.86m 9ft 5in	2.86m 9ft 5in	2.86m 9ft 5in
Turning Radius(Inside/Outside)	2.35m/5.20m 7ft 9in/17ft 1in	2.35m/5.20m 7ft 9in/17ft 1in	2.35m/5.20m 7ft 9in/17ft 1in	2.35m/5.20m 7ft 9in/17ft 1in
Tyres	33×12-20	33×12-20	315/55/D20	315/55/D20
Performance				
S.W.L	680kg 1499lb	680kg 1499lb	680kg 1499lb	680kg 1499lb
S.W.L On Extension	227kg 500lb	227kg 500lb	227kg 500lb	227kg 500lb
Max. Occupants (Indoor/Outdoor) CE	7/7	7/7	7/7	7/7
Max. Occupants (Indoor/Outdoor) ANSI92.20	7/7	7/7	7/7	7/7
Gradeability	50%	40%	40%	40%
Travel Speed(Stowed)	6.0km/h 3.73mph	6.0km/h 3.73mph	5.0km/h 3.1mph	6.0km/h 3.73mph
Travel Speed(Raised)	1.1km/h 0.68mph	1.0km/h 0.62mph	1.0km/h 0.62mph	1.0km/h 0.62mph
Max. Working Slope	2°/3°	2°/3°	2°/3°	2°/3°
Up/Down Speed	70/52sec	70/55sec	73/62sec	70/62sec
Weight				
Overall Weight(Without Outriggers)	7000kg 15432lb	7300kg 16093lb	6970kg 15366lb	7440kg 16402lb
Overall Weight(With Outriggers)	7900kg 17416lb	8200kg 18077lb	7870kg 17350lb	8340kg 18386lb
Power				
Diesel Engine	36.8kW/2700rpm	/	18.2kW/3000rpm	/
Diesel Tank	100L 26gal	/	100L 26gal	/
Hydraulic Tank	130L 34gal	130L 34gal	120L 31gal	120L 31gal
Battery(Lead-acid Battery)	/	48V/450Ah	/	48V/450Ah
Charger	/	48V/60A	/	48V/60A
Driving Motor	/	4×32VAC/3.3kW	/	32VAC/9kW
Lifting Motor	/	2×48VDC/8.0kW	/	32VAC/15kW

Engine Electric

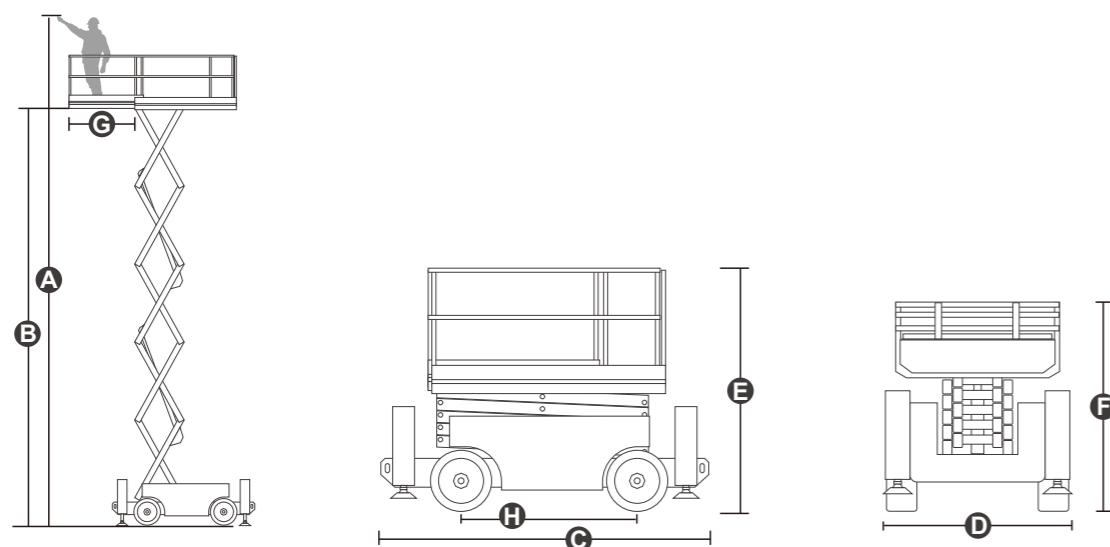

Model	JCPT1418RT	JCPT1418DC
Dimension		
Max. Working Height (Indoor) CE,ANSI92.20 A	14.30m 46ft 11in	14.30m 46ft 11in
Max. Working Height (Outdoor) ANSI92.20 B	14.30m 46ft 11in	14.30m 46ft 11in
Max. Platform Height (Indoor) CE,ANSI92.20	12.30m 40ft 4in	12.30m 40ft 4in
Max. Platform Height (Outdoor) ANSI92.20	12.30m 40ft 4in	12.30m 40ft 4in
Overall Length(Without Outriggers)	3.19m 10ft 6in	3.19m 10ft 6in
Overall Length(With Outriggers) C	3.84m 12ft 7in	3.84m 12ft 7in
Overall Width D	1.76m 5ft 9in	1.76m 5ft 9in
Overall Height(Rails Up) E	2.74m 9ft	2.74m 9ft
Overall Height(Rails Down) F	1.97m 6ft 6in	1.97m 6ft 6in
Platform Size(L×W)	2.88m×1.52m 9ft 5in × 5ft	2.88m×1.52m 9ft 5in × 5ft
Platform Extension Size G	1.43m 4ft 8in	1.43m 4ft 8in
Ground Clearance(Stowed/Raised)	0.24m 9in	0.24m 9in
Wheelbase H	2.29m 7ft 6in	2.29m 7ft 6in
Turning Radius(Inside/Outside)	2.15m/4.85m 7ft 1in/15ft 11in	2.15m/4.85m 7ft 1in/15ft 11in
Tyres	26×12-16.5	26×12-16.5
Performance		
S.W.L	363kg 800lb	363kg 800lb
S.W.L On Extension	136kg 299lb	136kg 299lb
Max. Occupants (Indoor/Outdoor) CE	3/2	3/2
Max. Occupants (Indoor/Outdoor) ANSI92.20	3/2	3/2
Gradeability	40%	40%
Travel Speed(Stowed)	5.0km/h 3.10mph	6.0km/h 3.73mph
Travel Speed(Raised)	0.45km/h 0.28mph	0.45km/h 0.28mph
Max. Working Slope	1.5°/3°	1.5°/3°
Up/Down Speed	45/46sec	45/46sec
Weight		
Overall Weight(Without Outriggers)	5050kg 11133lb	5150kg 11353lb
Overall Weight(With Outriggers)	5050kg 11133lb	5150kg 11353lb
Power		
Diesel Engine	18.2kW/3000rpm	/
Diesel Tank	47L 12.4gal	/
Hydraulic Tank	71L 18.7gal	71L 18.7gal
Battery(Lead-acid Battery)	/	48V/320Ah
Charger	/	48V/35A
Driving Motor	/	2×32VAC/3.3kW
Lifting Motor	/	48VDC/3.8kW

Engine Electric

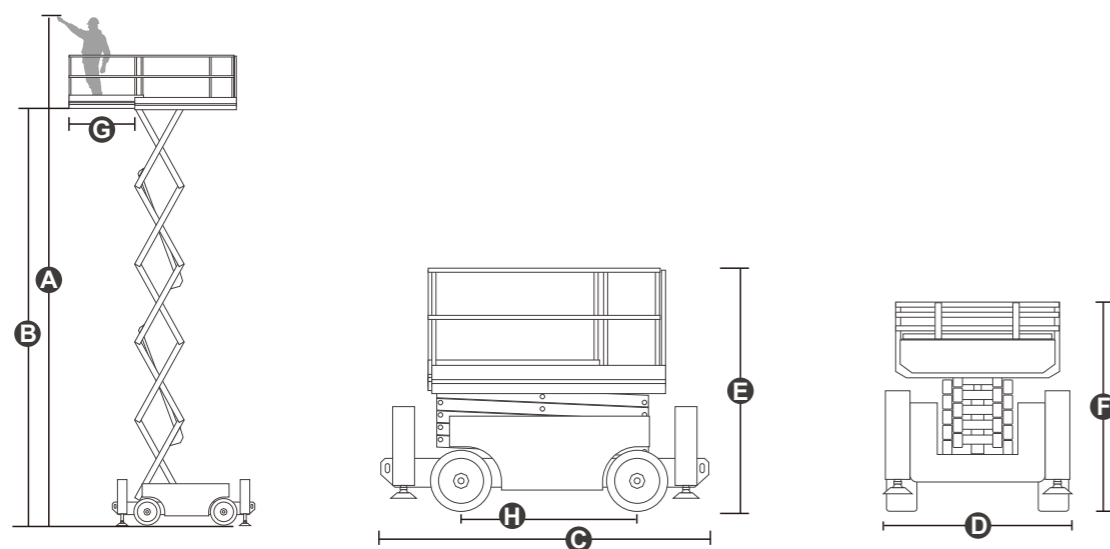

Model	JCPT1218RT	JCPT1218DC
Dimension		
Max. Working Height (Indoor) CE,ANSI92.20 A	12.00m 39ft 4in	12.00m 39ft 4in
Max. Working Height (Outdoor) ANSI92.20 B	12.00m 39ft 4in	12.00m 39ft 4in
Max. Platform Height (Indoor) CE,ANSI92.20	10.00m 32ft 10in	10.00m 32ft 10in
Max. Platform Height (Outdoor) ANSI92.20	10.00m 32ft 10in	10.00m 32ft 10in
Overall Length(Without Outriggers)	3.19m 10ft 6in	3.19m 10ft 6in
Overall Length(With Outriggers) C	3.84m 12ft 7in	3.84m 12ft 7in
Overall Width D	1.76m 5ft 9in	1.76m 5ft 9in
Overall Height(Rails Up) E	2.59m 8ft 6in	2.59m 8ft 6in
Overall Height(Rails Down) F	1.82m 6ft	1.82m 6ft
Platform Size(L×W)	2.88m×1.52m 9ft 5in × 5ft	2.88m×1.52m 9ft 5in × 5ft
Platform Extension Size G	1.43m 4ft 8in	1.43m 4ft 8in
Ground Clearance(Stowed/Raised)	0.24m 9in	0.24m 9in
Wheelbase H	2.29m 7ft 6in	2.29m 7ft 6in
Turning Radius(Inside/Outside)	2.15m/4.85m 7ft 1in/15ft 11in	2.15m/4.85m 7ft 1in/15ft 11in
Tyres	26×12-16.5	26×12-16.5
Performance		
S.W.L	454kg 1000lb	454kg 1000lb
S.W.L On Extension	136kg 299lb	136kg 299lb
Max. Occupants (Indoor/Outdoor) CE	4/2	4/2
Max. Occupants (Indoor/Outdoor) ANSI92.20	4/2	4/2
Gradeability	40%	40%
Travel Speed(Stowed)	5.0km/h 3.10mph	6.0km/h 3.73mph
Travel Speed(Raised)	0.45km/h 0.28mph	0.45km/h 0.28mph
Max. Working Slope	1.5°/3°	1.5°/3°
Up/Down Speed	38/46sec	40/46sec
Weight		
Overall Weight(Without Outriggers)	3900kg 8598lb	4135kg 9116lb
Overall Weight(With Outriggers)	4300kg 9479lb	4400kg 9700lb
Power		
Diesel Engine	18.2kW/3000rpm	/
Diesel Tank	47L 12.4gal	/
Hydraulic Tank	71L 18.7gal	71L 18.7gal
Battery(Lead-acid Battery)	/	48V/320Ah
Charger	/	48V/35A
Driving Motor	/	2×32VAC/3.3kW
Lifting Motor	/	48VDC/3.8kW

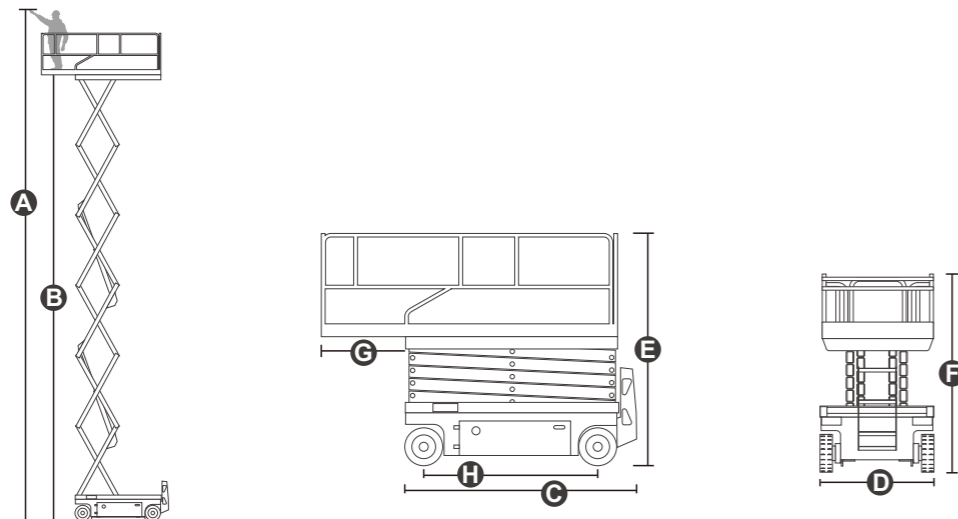

Model	JCPT1614AC	JCPT1614HA	JCPT1614AC ⁺	JCPT1614PA
Dimension				
Max. Working Height (Indoor) CE,ANSI92.20 A	15.70m 51ft 6in	15.70m 51ft 6in	15.70m 51ft 6in	15.70m 51ft 6in
Max. Working Height (Outdoor) ANSI92.20 B	12.00m 39ft 4in	12.00m 39ft 4in	11.00m 36ft 1in	12.70m 39ft 4in
Max. Platform Height (Indoor) CE,ANSI92.20	13.70m 44ft 11in	13.70m 44ft 11in	13.70m 44ft 11in	13.70m 44ft 11in
Max. Platform Height (Outdoor) ANSI92.20	10.00m 32ft 10in	10.00m 32ft 10in	9.00m 29ft 6in	10.70m 35ft 1in
Overall Length C	2.84m 9ft 4in	2.84m 9ft 4in	2.84m 9ft 4in	2.84m 9ft 4in
Overall Width D	1.39m 4ft 7in	1.39m 4ft 7in	1.39m 4ft 7in	1.39m 4ft 7in
Overall Height(Rails Up) E	2.62m 8ft 7in	2.62m 8ft 7in	2.62m 8ft 7in	2.62m 8ft 7in
Overall Height(Rails Down) F	2.09m 6ft 10in	2.09m 6ft 10in	2.09m 6ft 10in	2.09m 6ft 10in
Platform Size(L×W)	2.64m×1.12m 8ft 8in×3ft 8in	2.64m×1.12m 8ft 8in×3ft 8in	2.64m×1.12m 8ft 8in×3ft 8in	2.64m×1.12m 8ft 8in×3ft 8in
Platform Extension Size G	0.90m 2ft 11in	0.90m 2ft 11in	0.90m 2ft 11in	0.90m 2ft 11in
Ground Clearance(Stowed/Raised)	0.10m/0.019m 4in/1in	0.10m/0.019m 4in/1in	0.10m/0.019m 4in/1in	0.10m/0.019m 4in/1in
Wheelbase H	2.22m 7ft 3in	2.22m 7ft 3in	2.24m 7ft 4in	2.22m 7ft 3in
Turning Radius(Inside/Outside)	0m/2.70m 0in/8ft 10in	0m/2.70m 0in/8ft 10in	0m/2.70m 0in/8ft 10in	0m/2.70m 0in/8ft 10in
Tyres	Φ381×127mm	Φ381×127mm	Φ381×127mm	Φ381×127mm
Performance				
S.W.L	250kg 551lb	250kg 551lb	350kg 772lb	250kg 551lb
S.W.L On Extension	113kg 249lb	113kg 249lb	136kg 300lb	113kg 249lb
Max. Occupants (Indoor/Outdoor) CE	2/0	2/0	2/0	2/1
Max. Occupants (Indoor/Outdoor) ANSI92.20	2/1	2/1	2/1	/
Gradeability	25%	25%	25%	25%
Travel Speed(Stowed)	5.0km/h 3.10mph	3.5km/h 2.17mph	6.0km/h 3.73mph	5.0km/h 3.10mph
Travel Speed(Raised)	0.8km/h 0.50mph	0.8km/h 0.50mph	0.8km/h 0.50mph	0.8km/h 0.50mph
Max. Working Slope	1.5°/3°	1.5°/3°	1.5°/3°	1.5°/3°
Up/Down Speed	72/67sec	72/67sec	65/66sec	62/62sec
Weight				
Overall Weight(Lead-acid Battery)	3470kg 7650lb	3440kg 7583lb	/	3700kg 8157lb
Overall Weight(Lithium Battery)	3470kg 7650lb	3440kg 7583lb	3500kg 7716lb	/
Power				
Hydraulic Tank	20L 5.3gal	20L 5.3gal	20L 5.3gal	/
Battery(Lead-acid Battery)	24V/240AH	24V/240AH	/	24V/240AH
Battery(Lithium Battery)	24V/220AH	24V/220AH	28.8V/175AH	/
Charger	24V/30A	24V/30A	28V/30A	24V/30A
Driving Motor	15VAC/0.87kW	/	2×15VAC/0.87kW	2×15VAC/0.87kW
Lifting Motor	15V/3.5kW	15VAC/3.5kW	15VAC/3.42kw	24VDC/1.8kw

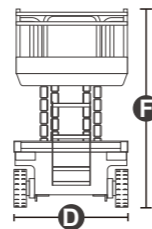
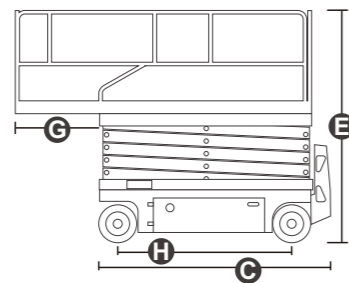
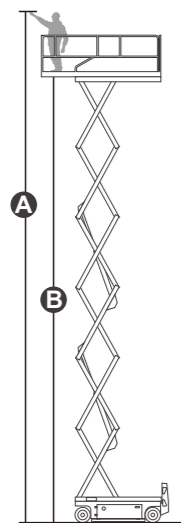
Electric  Oil-free 

Model	JCPT1612AC	JCPT1612HA	JCPT1612AC ⁺
Dimension			
Max. Working Height (Indoor) CE,ANSI92.20 A	15.70m 51ft 6in	15.70m 51ft 6in	15.70m 51ft 6in
Max. Working Height (Outdoor) ANSI92.20 B	11.00m 36ft 1in	11.00m 36ft 1in	9.00m 29ft 6in
Max. Platform Height (Indoor) CE,ANSI92.20	13.70m 44ft 11in	13.70m 44ft 11in	13.70m 44ft 11in
Max. Platform Height (Outdoor) ANSI92.20	9.00m 29ft 6in	9.00m 29ft 6in	7.00m 23ft
Overall Length C	2.84m 9ft 4in	2.84m 9ft 4in	2.84m 9ft 4in
Overall Width D	1.25m 4ft 1in	1.25m 4ft 1in	1.25m 4ft 1in
Overall Height(Rails Up) E	2.62m 8ft 7in	2.62m 8ft 7in	2.62m 8ft 7in
Overall Height(Rails Down) F	2.09m 6ft 10in	2.09m 6ft 10in	2.09m 6ft 10in
Platform Size(L×W)	2.64m×1.12m 8ft 8in×3ft 8in	2.64m×1.12m 8ft 8in×3ft 8in	2.64m×1.12m 8ft 8in×3ft 8in
Platform Extension Size G	0.90m 2ft 11in	0.90m 2ft 11in	0.90m 2ft 11in
Ground Clearance(Stowed/Raised)	0.10m/0.019m 4in/1in	0.10m/0.019m 4in/1in	0.10m/0.019m 4in/1in
Wheelbase H	2.22m 7ft 3in	2.22m 7ft 3in	2.24m 7ft 4in
Turning Radius(Inside/Outside)	0m/2.65m 0in/8ft 8in	0m/2.65m 0in/8ft 8in	0m/2.65m 0in/8ft 8in
Tyres	Φ381×127mm	Φ381×127mm	Φ381×127mm
Performance			
S.W.L	250kg 551lb	250kg 551lb	350kg 772lb
S.W.L On Extension	113kg 249lb	113kg 249lb	136kg 300lb
Max. Occupants (Indoor/Outdoor) CE	2/0	2/0	2/0
Max. Occupants (Indoor/Outdoor) ANSI92.20	2/1	2/1	2/1
Gradeability	25%	25%	25%
Travel Speed(Stowed)	5.0km/h 3.10mph	3.5km/h 2.17mph	6.0km/h 3.73mph
Travel Speed(Raised)	0.8km/h 0.50mph	0.8km/h 0.50mph	0.8km/h 0.50mph
Max. Working Slope	1.5°/3°	1.5°/3°	1.5°/3°
Up/Down Speed	70/67sec	72/67sec	68/68sec
Weight			
Overall Weight(Lead-acid Battery)	3360kg 7407lb	3330kg 7341lb	/
Overall Weight(Lithium Battery)	3360kg 7407lb	3330kg 7341lb	3390kg 7474lb
Power			
Hydraulic Tank	20L 5.3gal	20L 5.3gal	20L 5.3gal
Battery(Lead-acid Battery)	24V/240AH	24V/240AH	/
Battery(Lithium Battery)	24V/220AH	24V/220AH	28.8V/175AH
Charger	24V/30A	24V/30A	28V/30A
Driving Motor	2×15VAC/0.87kW	/	2×15VAC/0.87kW
Lifting Motor	15VAC/3.5kW	15VAC/3.5kW	15VAC/3.42kW

Electric Oil-free

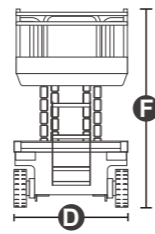
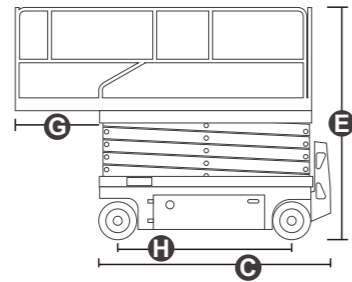
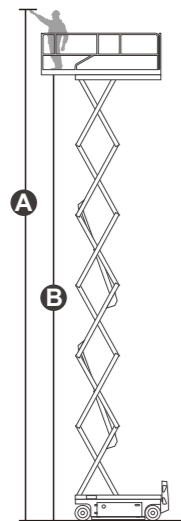

Model	JCPT1612ACS	JCPT1612HAS	JCPT1612PA
Dimension			
Max. Working Height (Indoor) CE,ANSI92.20 A	15.70m 51ft 6in	15.70m 51ft 6in	15.70m 51ft 6in
Max. Working Height (Outdoor) ANSI92.20 B	15.70m 51ft 6in	9.00m 29ft 6in	11.00m 36ft 1in
Max. Platform Height (Indoor) CE,ANSI92.20	13.70m 44ft 11in	13.70m 44ft 11in	13.70m 44ft 11in
Max. Platform Height (Outdoor) ANSI92.20	13.70m 44ft 11in	7.00m 22ft 11in	9.00m 29ft 6in
Overall Length C	2.48m 9ft 4in	2.48m 9ft 4in	2.84m 9ft 4in
Overall Width D	1.19m 3ft 11in	1.19m 3ft 11in	1.25m 4ft 1in
Overall Height(Rails Up) E	2.75m 9ft	2.75m 9ft	2.62m 8ft 7in
Overall Height(Rails Down) F	2.22m 7ft 3in	2.22m 7ft 3in	2.09m 6ft 10in
Platform Size(L×W)	2.27m×1.12m 7ft 5in×3ft 8in	2.27m×1.12m 7ft 5in×3ft 8in	2.64m×1.12m 8ft 8in×3ft 8in
Platform Extension Size G	0.90m 2ft 11in	0.90m 2ft 11in	0.90m 2ft 11in
Ground Clearance(Stowed/Raised)	0.10m/0.019m 4in/1in	0.10m/0.019m 4in/1in	0.10m/0.019m 4in/1in
Wheelbase H	1.87m 6ft 2in	1.87m 6ft 2in	2.22m 7ft 3in
Turning Radius(Inside/Outside)	0m/2.20m 0in/7ft 3in	0m/2.20m 0in/7ft 3in	0m/2.65m 0in/8ft 8in
Tyres	Φ381×127mm	Φ381×127mm	Φ381×127mm
Performance			
S.W.L	250kg 551lb	250kg 551lb	250kg 551lb
S.W.L On Extension	113kg 249lb	113kg 249lb	113kg 249lb
Max. Occupants (Indoor/Outdoor) CE	2/0	2/0	2/0
Max. Occupants (Indoor/Outdoor) ANSI92.20	/	/	2/1
Gradeability	25%	25%	25%
Travel Speed(Stowed)	5.0km/h 3.10mph	3.5km/h 2.17mph	5.0km/h 3.10mph
Travel Speed(Raised)	0.4km/h 0.25mph	0.4km/h 0.25mph	0.8km/h 0.50mph
Max. Working Slope	1.5°/3°	1.5°/3°	1.5°/3°
Up/Down Speed	84/60sec	76/60sec	62/62sec
Weight			
Overall Weight(Lead-acid Battery)	3230kg 7120lb	3220kg 7098lb	3580kg 7893lb
Overall Weight(Lithium Battery)	3230kg 7120lb	/	3580kg 7893lb
Power			
Hydraulic Tank	20L 5.3gal	20L 5.3gal	/
Battery(Lead-acid Battery)	24V/240AH	24V/240AH	24V/240AH
Battery(Lithium Battery)	24V/220AH	24V/220AH	24V/220AH
Charger	24V/30A	24V/30A	24V/30A
Driving Motor	2×15VAC/0.87kW	/	2×15VAC/0.87kW
Lifting Motor	15VAC/3.5kW	15VAC/3.5kW	24VDC/1.8kW

Electric

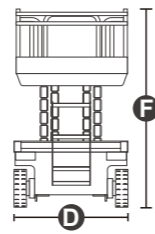
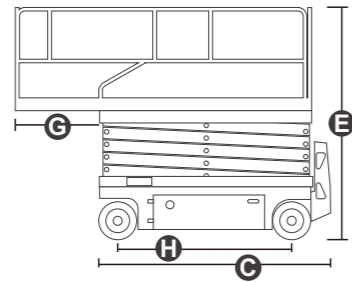
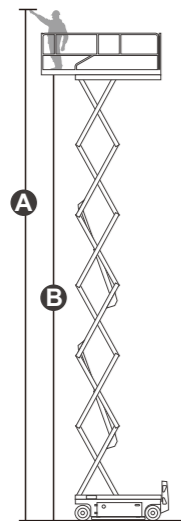

Model	JCPT1412AC	JCPT1412HA	JCPT1412AC ⁺
Dimension			
Max. Working Height (Indoor) CE,ANSI92.20 A	13.80m 45ft 3in	13.80m 45ft 3in	13.80m 45ft 3in
Max. Working Height (Outdoor) ANSI92.20 B	11.20m 36ft 9in	11.20m 36ft 9in	11.20m 36ft 9in
Max. Platform Height (Indoor) CE,ANSI92.20	11.80m 38ft 9in	11.80m 38ft 9in	11.80m 38ft 9in
Max. Platform Height (Outdoor) ANSI92.20	9.20m 30ft 2in	9.20m 30ft 2in	9.20m 30ft 2in
Overall Length C	2.48m 8ft 2in	2.48m 8ft 2in	2.48m 8ft 2in
Overall Width D	1.19m 3ft 11in	1.19m 3ft 11in	1.19m 3ft 11in
Overall Height(Rails Up) E	2.62m 8ft 7in	2.62m 8ft 7in	2.62m 8ft 7in
Overall Height(Rails Down) F	2.09m 6ft 10in	2.09m 6ft 10in	2.09m 6ft 10in
Platform Size(L×W)	2.27m×1.12m 7ft 5in×3ft 8in	2.27m×1.12m 7ft 5in×3ft 8in	2.27m×1.12m 7ft 5in×3ft 8in
Platform Extension Size G	0.90m 2ft 11in	0.90m 2ft 11in	0.90m 2ft 11in
Ground Clearance(Stowed/Raised)	0.10m/0.019m 4in/1in	0.10m/0.019m 4in/1in	0.10m/0.019m 4in/1in
Wheelbase H	1.87m 6ft 2in	1.87m 6ft 2in	1.87m 6ft 2in
Turning Radius(Inside/Outside)	0m/2.20m 0in/7ft 3in	0m/2.20m 0in/7ft 3in	0m/2.10m 0in/6ft 11in
Tyres	Φ381×127mm	Φ381×127mm	Φ381×127mm
Performance			
S.W.L	320kg 705lb	320kg 705lb	350kg 772lb
S.W.L On Extension	113kg 249lb	113kg 249lb	113kg 249lb
Max. Occupants (Indoor/Outdoor) CE	3/0	3/0	3/0
Max. Occupants (Indoor/Outdoor) ANSI92.20	2/1	2/1	3/1
Gradeability	25%	25%	25%
Travel Speed(Stowed)	5.0km/h 3.10mph	3.5km/h 2.17mph	6.0km/h 3.73mph
Travel Speed(Raised)	0.8km/h 0.50mph	0.8km/h 0.50mph	0.8km/h 0.50mph
Max. Working Slope	1.5°/3°	1.5°/3°	1.5°/3°
Up/Down Speed	55/40sec	58/40sec	52/52sec
Weight			
Overall Weight(Lead-acid Battery)	2990kg 6591lb	2980kg 6569lb	/
Overall Weight(Lithium Battery)	2990kg 6591lb	2980kg 6569lb	3210kg 7077lb
Power			
Hydraulic Tank	20L 5.3gal	20L 5.3gal	20L 5.3gal
Battery(Lead-acid Battery)	24V/240AH	24V/240AH	/
Battery(Lithium Battery)	24V/220AH	24V/220AH	28.8V/175AH
Charger	24V/30A	24V/30A	28V/30A
Driving Motor	2×15VAC/0.87kW	/	2×15VAC/0.87kW
Lifting Motor	15VAC/3.5kW	15VAC/3.5kW	15VAC/3.42kW

Electric

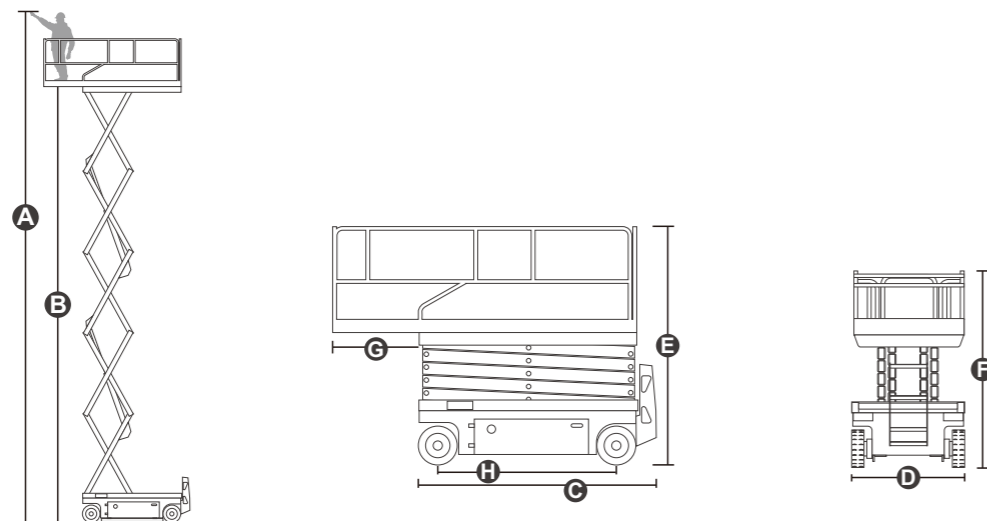

Model	JCPT1212AC	JCPT1212HA	JCPT1212AC ⁺
Dimension			
Max. Working Height (Indoor) CE,ANSI92.20 A	12.00m 39ft 4in	12.00m 39ft 4in	12.00m 39ft 4in
Max. Working Height (Outdoor) ANSI92.20 B	12.00m 39ft 4in	12.00m 39ft 4in	12.00m 39ft 4in
Max. Platform Height (Indoor) CE,ANSI92.20	10.00m 32ft 10in	10.00m 32ft 10in	10.00m 32ft 10in
Max. Platform Height (Outdoor) ANSI92.20	10.00m 32ft 10in	10.00m 32ft 10in	10.00m 32ft 10in
Overall Length C	2.48m 8ft 2in	2.48m 8ft 2in	2.48m 8ft 2in
Overall Width D	1.15m 3ft 9in	1.15m 3ft 9in	1.15m 3ft 9in
Overall Height(Rails Up) E	2.49m 8ft 2in	2.49m 8ft 2in	2.49m 8ft 2in
Overall Height(Rails Down) F	1.96m 6ft 5in	1.96m 6ft 5in	1.96m 6ft 5in
Platform Size(L×W)	2.27m×1.12m 7ft 5in×3ft 8in	2.27m×1.12m 7ft 5in×3ft 8in	2.27m×1.12m 7ft 5in×3ft 8in
Platform Extension Size G	0.90m 2ft 11in	0.90m 2ft 11in	0.90m 2ft 11in
Ground Clearance(Stowed/Raised)	0.10m/0.019m 4in/1in	0.10m/0.019m 4in/1in	0.10m/0.019m 4in/1in
Wheelbase H	1.87m 6ft 2in	1.87m 6ft 2in	1.87m 6ft 2in
Turning Radius(Inside/Outside)	0m/2.20m 0in/7ft 3in	0m/2.20m 0in/7ft 3in	0m/2.10m 0in/6ft 11in
Tyres	Φ381×127mm	Φ381×127mm	Φ381×127mm
Performance			
S.W.L	320kg 705lb	320kg 705lb	350kg 772lb
S.W.L On Extension	113kg 249lb	113kg 249lb	113kg 249lb
Max. Occupants (Indoor/Outdoor) CE	2/1	2/1	2/1
Max. Occupants (Indoor/Outdoor) ANSI92.20	/	/	/
Gradeability	25%	25%	25%
Travel Speed(Stowed)	5.0km/h 3.10mph	3.5km/h 2.17mph	6.0km/h 3.73mph
Travel Speed(Raised)	0.8km/h 0.50mph	0.8km/h 0.50mph	0.8km/h 0.50mph
Max. Working Slope	1.5°/3°	1.5°/3°	1.5°/3°
Up/Down Speed	54/45sec	55/49sec	54/51sec
Weight			
Overall Weight(Lead-acid Battery)	3060kg 6746lb	3050kg 6724lb	/
Overall Weight(Lithium Battery)	3060kg 6746lb	3050kg 6724lb	3060kg 6746lb
Power			
Hydraulic Tank	20L 5.3gal	20L 5.3gal	20L 5.3gal
Battery(Lead-acid Battery)	24V/200AH	24V/200AH	/
Battery(Lithium Battery)	24V/220AH	24V/220AH	28.8V/175AH
Charger	24V/30A	24V/30A	28V/30A
Driving Motor	2×15VAC/0.87kW	/	2×15VAC/0.87kW
Lifting Motor	15VAC/3.5kW	15VAC/3.5kW	15VAC/3.42kW

Electric Oil-free

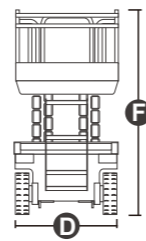
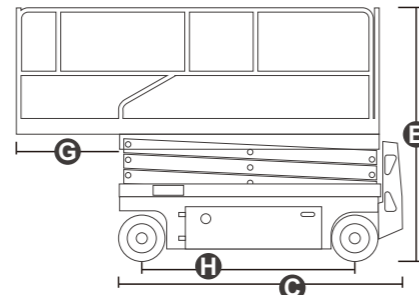
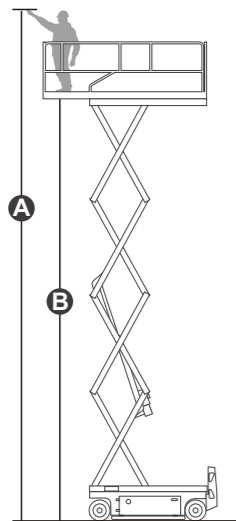

Model	JCPT1012AG	JCPT1012HA	JCPT1012AG+	JCPT1012PA
Dimension				
Max. Working Height (Indoor) CE,ANSI92.20 A	10.00m 32ft 10in	10.00m 32ft 10in	10.00m 32ft 10in	10.00m 32ft 10in
Max. Working Height (Outdoor) ANSI92.20 B	10.00m 32ft 10in	10.00m 32ft 10in	10.00m 32ft 10in	10.00m 32ft 10in
Max. Platform Height (Indoor) CE,ANSI92.20	8.00m 26ft 3in	8.00m 26ft 3in	8.00m 26ft 3in	8.00m 26ft 3in
Max. Platform Height (Outdoor) ANSI92.20	8.00m 26ft 3in	8.00m 26ft 3in	8.00m 26ft 3in	8.00m 26ft 3in
Overall Length C	2.48m 8ft 2in	2.48m 8ft 2in	2.48m 8ft 2in	2.48m 8ft 2in
Overall Width D	1.15m 3ft 9in	1.15m 3ft 9in	1.15m 3ft 9in	1.15m 3ft 9in
Overall Height(Rails Up) E	2.36m 7ft 9in	2.36m 7ft 9in	2.36m 7ft 9in	2.36m 7ft 9in
Overall Height(Rails Down) F	1.83m 6ft	1.83m 6ft	1.83m 6ft	1.83m 6ft
Platform Size(L×W)	2.27m×1.12m 7ft 5in×3ft 8in	2.27m×1.12m 7ft 5in×3ft 8in	2.27m×1.12m 7ft 5in×3ft 8in	2.27m×1.12m 7ft 5in×3ft 8in
Platform Extension Size G	0.90m 2ft 11in	0.90m 2ft 11in	0.90m 2ft 11in	0.90m 2ft 11in
Ground Clearance(Stowed/Raised)	0.10m/0.019m 4in/1in	0.10m/0.019m 4in/1in	0.10m/0.019m 4in/1in	0.10m/0.019m 4in/1in
Wheelbase H	1.87m 6ft 2in	1.87m 6ft 2in	1.87m 6ft 2in	1.87m 6ft 2in
Turning Radius(Inside/Outside)	0m/2.20m 0in/7ft 3in	0m/2.20m 0in/7ft 3in	0m/2.10m 0in/6ft 11in	0m/2.20m 0in/7ft 3in
Tyres	Φ381×127mm	Φ381×127mm	Φ381×127mm	Φ381×127mm
Performance				
S.W.L	450kg 992lb	450kg 992lb	450kg 992lb	350kg 772lb
S.W.L On Extension	113kg 249lb	113kg 249lb	113kg 249lb	113kg 249lb
Max. Occupants (Indoor/Outdoor) CE	2/2	2/2	2/2	2/2
Max. Occupants (Indoor/Outdoor) ANSI92.20	/	/	/	/
Gradeability	25%	25%	25%	25%
Travel Speed(Stowed)	5.0km/h 3.10mph	3.5km/h 2.17mph	6.0km/h 3.73mph	5.0km/h 3.10mph
Travel Speed(Raised)	0.8km/h 0.50mph	0.8km/h 0.50mph	0.8km/h 0.50mph	0.8km/h 0.50mph
Max. Working Slope	1.5°/3°	1.5°/3°	1.5°/3°	1.5°/3°
Up/Down Speed	34/30sec	34/30sec	33/35sec	34/34sec
Weight				
Overall Weight(Lead-acid Battery)	2710kg 5974lb	2670kg 5886lb	/	2850kg 6283lb
Overall Weight(Lithium Battery)	2710kg 5974lb	2670kg 5886lb	2750kg 6063lb	/
Power				
Hydraulic Tank	20L 5.3gal	20L 5.3gal	20L 5.3gal	/
Battery(Lead-acid Battery)	24V/185AH	24V/185AH	/	24V/185AH
Battery(Lithium Battery)	24V/180AH	24V/180AH	28.8V/175AH	/
Charger	24V/30A	24V/30A	28V/30A	24V/30A
Driving Motor	2×15VAC/0.87kW	/	2×15VAC/0.87kW	2×15VAC/0.87kW
Lifting Motor	15VAC/3.5kW	15VAC/3.5kW	15VAC/3.42kW	24VDC/3.0kW

Electric Oil-free

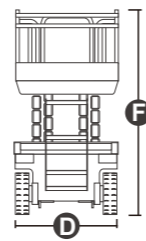
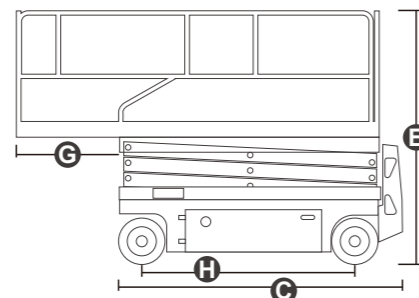
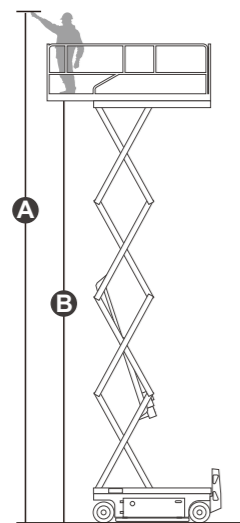

Model	JCPT1008AC	JCPT1008HA	JCPT1008ACS	JCPT1008AC ⁺	JCPT1008PA
Dimension					
Max. Working Height (Indoor) CE,ANSI92.20 A	10.00m 32ft 10in	10.00m 32ft 10in	9.60m 31ft 6in	10.00m 32ft 10in	10.00m 32ft 10in
Max. Working Height (Outdoor) ANSI92.20 B	8.10m 26ft 7in	8.10m 26ft 7in	/	8.10m 26ft 7in	8.10m 26ft 7in
Max. Platform Height (Indoor) CE,ANSI92.20	8.00m 26ft 3in	8.00m 26ft 3in	7.60m 24ft 11in	8.00m 26ft 3in	8.00m 26ft 3in
Max. Platform Height (Outdoor) ANSI92.20	6.10m 20ft	6.10m 20ft	/	6.10m 20ft	6.10m 20ft
Overall Length C	2.48m 8ft 2in	2.48m 8ft 2in	1.88m 6ft 2in	2.48m 8ft 2in	2.48m 8ft 2in
Overall Width D	0.83m 2ft 9in	0.83m 2ft 9in	0.81m 2ft 8in	0.83m 2ft 9in	0.83m 2ft 9in
Overall Height(Rails Up) E	2.36m 7ft 9in	2.36m 7ft 9in	2.32m 7ft 7in	2.36m 7ft 9in	2.36m 7ft 9in
Overall Height(Rails Down) F	2.00m 6ft 7in	2.00m 6ft 7in	1.99m 6ft 6in	1.90m 6ft 3in	2.00m 6ft 7in
Platform Size(L×W)	2.27m×0.81m 7ft 5in×2ft 8in	2.27m×0.81m 7ft 5in×2ft 8in	1.725m×0.74m 5ft 8in×2ft 5in	2.27m×0.81m 7ft 5in×2ft 8in	2.27m×0.81m 7ft 5in×2ft 8in
Platform Extension Size G	0.90m 2ft 11in	0.90m 2ft 11in	0.90m 2ft 11in	0.90m 2ft 11in	0.90m 2ft 11in
Ground Clearance(Stowed/Raised)	0.10m/0.019m 4in/1in	0.10m/0.019m 4in/1in	0.09m/0.016m 4in/1in	0.10m/0.019m 4in/1in	0.10m/0.019m 4in/1in
Wheelbase H	1.87m 6ft 2in	1.87m 6ft 2in	1.40m 4ft 7in	1.87m 6ft 2in	1.87m 6ft 2in
Turning Radius(Inside/Outside)	0m/2.10m 0in/6ft 11in	0m/2.10m 0in/6ft 11in	0m/1.70m 0m/5ft 7in	0m/2.10m 0in/6ft 11in	0m/2.10m 0in/6ft 11in
Tyres	Φ381×127mm	Φ381×127mm	Φ323×125mm	Φ381×127mm	Φ381×127mm
Performance					
S.W.L	230kg 507lb	230kg 507lb	230kg 507lb	250kg 551lb	230kg 507lb
S.W.L On Extension	113kg 249lb	113kg 249lb	113kg 249lb	113kg 249lb	113kg 249lb
Max. Occupants (Indoor/Outdoor) CE	2/0	2/0	2/0	2/0	2/0
Max. Occupants (Indoor/Outdoor) ANSI92.20	2/1	2/1	/	2/1	/
Gradeability	25%	25%	25%	25%	25%
Travel Speed(Stowed)	5.0km/h 3.10mph	3.5km/h 2.17mph	4.5km/h 2.80mph	6.0km/h 3.73mph	5.0km/h 3.10mph
Travel Speed(Raised)	0.8km/h 0.50mph	0.8km/h 0.50mph	0.4km/h 0.25mph	0.8km/h 0.50mph	0.8km/h 0.50mph
Max. Working Slope	1.5°/3°	1.5°/3°	1.5°/3°	1.5°/3°	1.5°/3°
Up/Down Speed	32/34sec	30/34sec	35/45sec	32/34sec	33/33sec
Weight					
Overall Weight(Lead-acid Battery)	2230kg 4916lb	2190kg 4828lb	2180kg 4806lb	/	2350kg 5180lb
Overall Weight(Lithium Battery)	2230kg 4916lb	2190kg 4828lb	/	2230kg 4916lb	/
Power					
Hydraulic Tank	20L 5.3gal	20L 5.3gal	11L 2.7gal	20L 5.3gal	/
Battery(Lead-acid Battery)	24V/185AH	24V/185AH	24V/185Ah	/	24V/185AH
Battery(Lithium Battery)	24V/180AH	24V/180AH	24V/180AH	28.8V/150AH	/
Charger	24V/30A	24V/30A	24V/30A	28V/30A	24V/30A
Driving Motor	2×15VAC/0.87kW	/	2×24VAC/0.5kW	2×15VAC/0.87kW	2×15VAC/0.87kW
Lifting Motor	15VAC/3.5kW	15VAC/3.5kW	24VAC/3.0kW	15VAC/3.42kW	24VDC/1.8kW

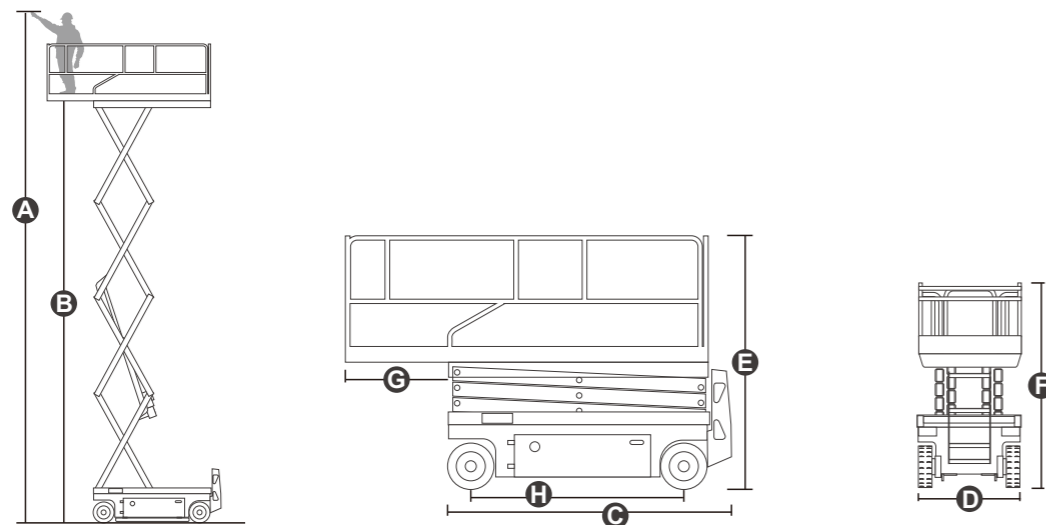

Model	JCPT0812AC	JCPT0812HA
Dimension		
Max. Working Height (Indoor) CE,ANSI92.20 A	8.00m 26ft 3in	8.00m 26ft 3in
Max. Working Height (Outdoor) ANSI92.20 B	8.00m 26ft 3in	8.00m 26ft 3in
Max. Platform Height (Indoor) CE,ANSI92.20	6.00m 19ft 8in	6.00m 19ft 8in
Max. Platform Height (Outdoor) ANSI92.20	6.00m 19ft 8in	6.00m 19ft 8in
Overall Length C	2.48m 8ft 2in	2.48m 8ft 2in
Overall Width D	1.15m 3ft 9in	1.15m 3ft 9in
Overall Height(Rails Up) E	2.23m 7ft 4in	2.23m 7ft 4in
Overall Height(Rails Down) F	1.70m 5ft 7in	1.70m 5ft 7in
Platform Size(L×W)	2.27m×1.12m 7ft 5in×3ft 8in	2.27m×1.12m 7ft 5in×3ft 8in
Platform Extension Size G	0.90m 2ft 11in	0.90m 2ft 11in
Ground Clearance(Stowed/Raised)	0.10m/0.019m 4in/1in	0.10m/0.019m 4in/1in
Wheelbase H	1.87m 6ft 2in	1.87m 6ft 2in
Turning Radius(Inside/Outside)	0m/2.20m 0in/7ft 3in	0m/2.20m 0in/7ft 3in
Tyres	Φ381×127mm	Φ381×127mm
Performance		
S.W.L	540kg 1190lb	540kg 1190lb
S.W.L On Extension	113kg 249lb	113kg 249lb
Max. Occupants (Indoor/Outdoor) CE	2/2	2/2
Max. Occupants (Indoor/Outdoor) ANSI92.20	/	/
Gradeability	25%	25%
Travel Speed(Stowed)	5.0km/h 3.10mph	3.5km/h 2.17mph
Travel Speed(Raised)	0.8km/h 0.50mph	0.8km/h 0.50mph
Max. Working Slope	1.5°/3°	1.5°/3°
Up/Down Speed	31/30sec	31/30sec
Weight		
Overall Weight(Lead-acid Battery)	1990kg 4387lb	1950kg 4299lb
Overall Weight(Lithium Battery)	1990kg 4387lb	1950kg 4299lb
Power		
Hydraulic Tank	20L 5.3gal	20L 5.3gal
Battery(Lead-acid Battery)	24V/185AH	24V/185AH
Battery(Lithium Battery)	24V/180AH	24V/180AH
Charger	24V/30A	24V/30A
Driving Motor	2×15VAC/0.87kW	/
Lifting Motor	15VAC/3.5kW	15VAC/3.5kW

Electric Oil-free

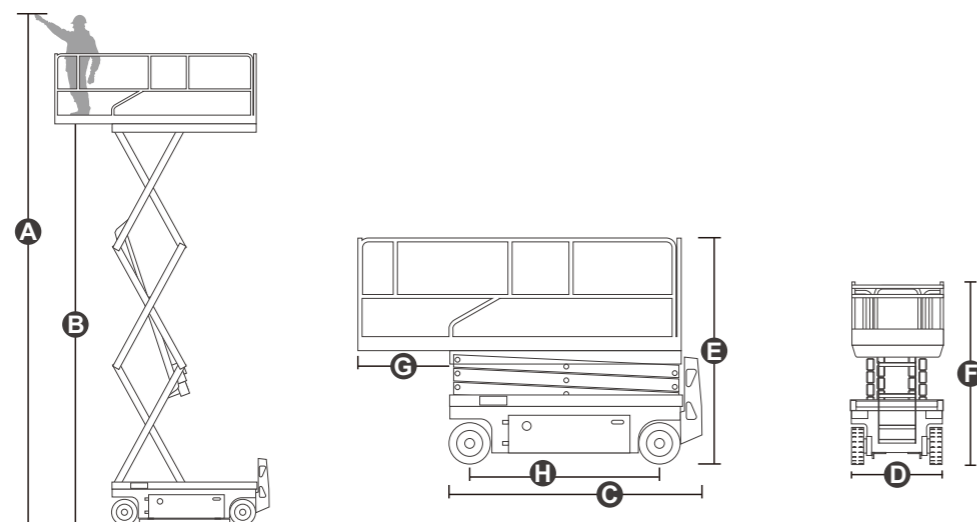

Model	JCPT0808AC	JCPT0808HA	JCPT0808AC ⁺	JCPT0808PA
Dimension				
Max. Working Height (Indoor) CE,ANSI92.20 A	8.00m 26ft 3in	8.00m 26ft 3in	8.00m 26ft 3in	8.00m 26ft 3in
Max. Working Height (Outdoor) ANSI92.20 B	8.00m 26ft 3in	8.00m 26ft 3in	8.00m 26ft 3in	8.00m 26ft 3in
Max. Platform Height (Indoor) CE,ANSI92.20	6.00m 19ft 8in	6.00m 19ft 8in	6.00m 19ft 8in	6.00m 19ft 8in
Max. Platform Height (Outdoor) ANSI92.20	6.00m 19ft 8in	6.00m 19ft 8in	6.00m 19ft 8in	6.00m 19ft 8in
Overall Length C	2.48m 8ft 2in	2.48m 8ft 2in	2.48m 8ft 2in	2.48m 8ft 2in
Overall Width D	0.83m 2ft 9in	0.83m 2ft 9in	0.83m 2ft 9in	0.83m 2ft 9in
Overall Height(Rails Up) E	2.23m 7ft 4in	2.23m 7ft 4in	2.23m 7ft 4in	2.28m 7ft 6in
Overall Height(Rails Down) F	1.87m 6ft 2in	1.87m 6ft 2in	1.77m 5ft 10in	1.92m 6ft 4in
Platform Size(L×W)	2.27m×0.81m 7ft 5in×2ft 8in	2.27m×0.81m 7ft 5in×2ft 8in	2.27m×0.81m 7ft 5in×2ft 8in	2.27m×0.81m 7ft 5in×2ft 8in
Platform Extension Size G	0.90m 2ft 11in	0.90m 2ft 11in	0.90m 2ft 11in	0.90m 2ft 11in
Ground Clearance(Stowed/Raised)	0.10m/0.019m 4in/1in	0.10m/0.019m 4in/1in	0.10m/0.019m 4in/1in	0.10m/0.019m 4in/1in
Wheelbase H	1.87m 6ft 2in	1.87m 6ft 2in	1.87m 6ft 2in	1.87m 6ft 2in
Turning Radius(Inside/Outside)	0m/2.10m 0in/6ft 11in	0m/2.10m 0in/6ft 11in	0m/2.10m 0in/6ft 11in	0m/2.10m 0in/6ft 11in
Tyres	Φ381×127mm	Φ381×127mm	Φ381×127mm	Φ381×127mm
Performance				
S.W.L	380kg 837lb	380kg 837lb	408kg 900lb	380kg 837lb
S.W.L On Extension	113kg 249lb	113kg 249lb	113kg 249lb	113kg 249lb
Max. Occupants (Indoor/Outdoor) CE	2/1	2/1	2/1	2/1
Max. Occupants (Indoor/Outdoor) ANSI92.20	/	/	/	/
Gradeability	25%	25%	25%	25%
Travel Speed(Stowed)	5.0km/h 3.10mph	3.5km/h 2.17mph	6.0km/h 3.73mph	5.0km/h 3.10mph
Travel Speed(Raised)	0.8km/h 0.50mph	0.8km/h 0.50mph	0.8km/h 0.50mph	0.8km/h 0.50mph
Max. Working Slope	1.5°/3°	1.5°/3°	1.5°/3°	1.5°/3°
Up/Down Speed	30/40sec	30/40sec	30/43sec	33/33sec
Weight				
Overall Weight(Lead-acid Battery)	2160kg 4761lb	2120kg 4673lb	/	2290kg 5048lb
Overall Weight(Lithium Battery)	2160kg 4761lb	2120kg 4673lb	2160kg 4761lb	/
Power				
Hydraulic Tank	20L 5.3gal	20L 5.3gal	20L 5.3gal	/
Battery(Lead-acid Battery)	24V/185AH	24V/185AH	/	24V/185AH
Battery(Lithium Battery)	24V/180AH	24V/180AH	28.8V/150AH	/
Charger	24V/30A	24V/30A	28V/30A	24V/30A
Driving Motor	2×15VAC/0.87kW	/	2×15VAC/0.87kW	2×15VAC/0.87kW
Lifting Motor	15VAC/3.5kW	15VAC/3.5kW	15VAC/3.42kW	24VDC/1.8kW

Electric Oil-free

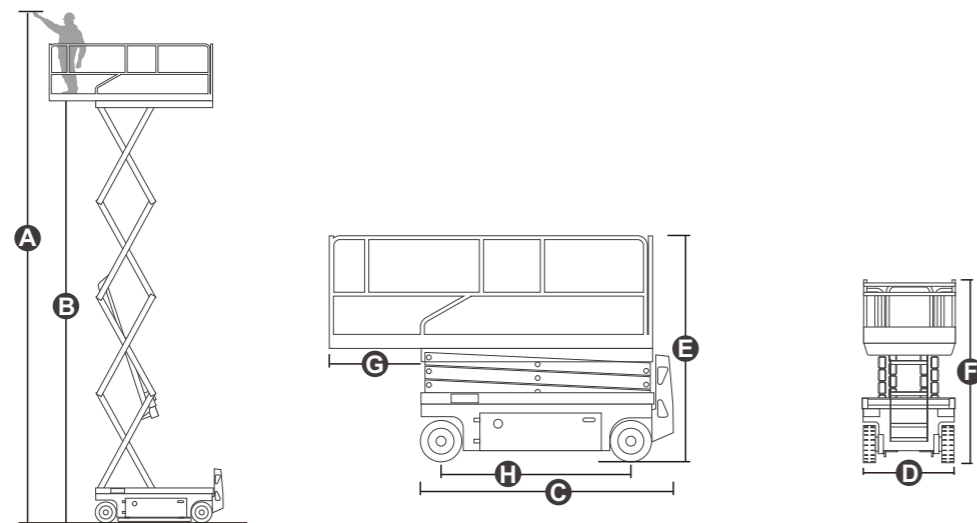

Model	JCPT0807AC	JCPT0807HA	JCPT0807AC ⁺	JCPT0807PA
Dimension				
Max. Working Height (Indoor) CE,ANSI92.20 A	7.80m 25ft 7in	7.80m 25ft 7in	7.80m 25ft 7in	7.80m 25ft 7in
Max. Working Height (Outdoor) ANSI92.20 B	7.80m 25ft 7in	7.80m 25ft 7in	7.80m 25ft 7in	7.80m 25ft 7in
Max. Platform Height (Indoor) CE,ANSI92.20	5.80m 19ft	5.80m 19ft	5.80m 19ft	5.80m 19ft
Max. Platform Height (Outdoor) ANSI92.20	5.80m 19ft	5.80m 19ft	5.80m 19ft	5.80m 19ft
Overall Length C	1.86m 6ft 1in	1.86m 6ft 1in	1.86m 6ft 1in	1.86m 6ft 1in
Overall Width D	0.76m 2ft 6in	0.76m 2ft 6in	0.76m 2ft 6in	0.76m 2ft 6in
Overall Height(Rails Up) E	2.15m 7ft 1in	2.15m 7ft 1in	2.15m 7ft 1in	2.15m 7ft 1in
Overall Height(Rails Down) F	1.83m 6ft	1.83m 6ft	1.83m 6ft	1.83m 6ft
Platform Size(L×W)	1.67m×0.74m 5ft 6in×2ft 5in	1.67m×0.74m 5ft 6in×2ft 5in	1.67m×0.74m 5ft 6in×2ft 5in	1.67m×0.74m 5ft 6in×2ft 5in
Platform Extension Size G	0.90m 2ft 11in	0.90m 2ft 11in	0.90m 2ft 11in	0.90m 2ft 11in
Ground Clearance(Stowed/Raised)	0.09m/0.016m 4in/1in	0.09m/0.016m 4in/1in	0.09m/0.016m 4in/1in	0.09m/0.016m 4in/1in
Wheelbase H	1.36m 4ft 6in	1.36m 4ft 6in	1.36m 4ft 6in	1.36m 4ft 6in
Turning Radius(Inside/Outside)	0m/1.64m 0in/5ft 5in	0m/1.64m 0in/5ft 5in	0m/1.64m 0in/5ft 5in	0m/1.64m 0in/5ft 5in
Tyres	Φ323×100mm	Φ323×100mm	Φ323×100mm	Φ323×100mm
Performance				
S.W.L	230kg 507lb	230kg 507lb	250kg 551lb	230kg 507lb
S.W.L On Extension	113kg 249lb	113kg 249lb	113kg 249lb	113kg 249lb
Max. Occupants (Indoor/Outdoor) CE	2/1	2/1	2/1	2/1
Max. Occupants (Indoor/Outdoor) ANSI92.20	/	/	/	/
Gradeability	25%	25%	25%	25%
Travel Speed(Stowed)	4.5km/h 2.80mph	4.0km/h 2.49mph	5.5km/h 3.41mph	4.5km/h 2.80mph
Travel Speed(Raised)	0.6km/h 0.37mph	0.6km/h 0.37mph	0.6km/h 0.37mph	0.6km/h 0.37mph
Max. Working Slope	1.5°/3°	1.5°/3°	1.5°/3°	1.5°/3°
Up/Down Speed	21/25sec	21/25sec	22/22sec	25/25sec
Weight				
Overall Weight(Lead-acid Battery)	1630kg 3593lb	1610kg 3549lb	/	1650kg 3637lb
Overall Weight(Lithium Battery)	1630kg 3593lb	1610kg 3549lb	1630kg 3594lb	/
Power				
Hydraulic Tank	6.5L 1.7gal	6.5L 1.7gal	7L 1.7gal	/
Battery(Lead-acid Battery)	24V/185AH	24V/185AH	/	24V/185AH
Battery(Lithium Battery)	24V/180AH	24V/180AH	28.8V/125AH	/
Charger	24V/30A	24V/30A	28V/30A	24V/30A
Driving Motor	2×15VAC/0.5kW	/	2×15VAC/0.5kW	2×15VAC/0.5kW
Lifting Motor	15VAC/3.0kW	15VAC/3.0kW	15VAC/3.0kW	24VDC/1.4kW

Electric Oil-free

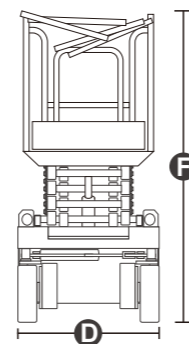
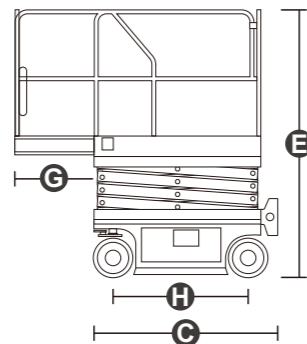
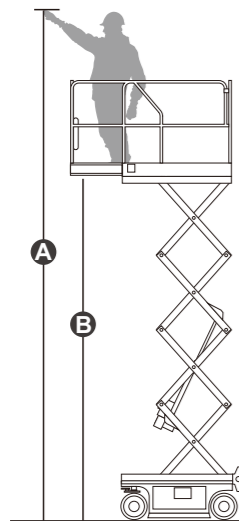
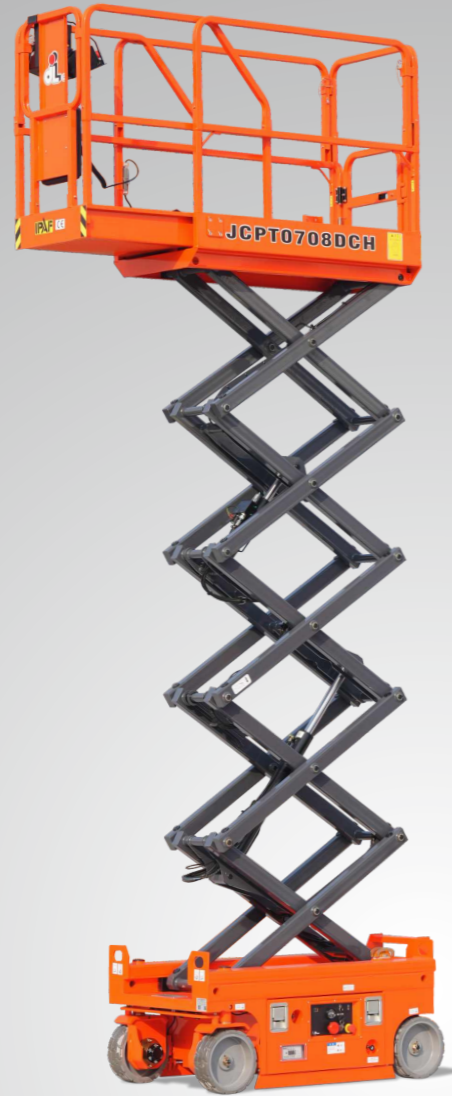

Model	JCPT0708DCM	JCPT0708DCH	JCPT0708PA	JCPT0708PAH
Dimension				
Max. Working Height (Indoor) CE,ANSI92.20 A	7.60m 24ft 11in	7.60m 24ft 11in	7.60m 24ft 11in	7.60m 24ft 11in
Max. Working Height (Outdoor) ANSI92.20 B	6.60m 21ft 8in	6.60m 21ft 8in	6.60m 21ft 8in	6.60m 21ft 8in
Max. Platform Height (Indoor) CE,ANSI92.20	5.60m 18ft 4in	5.60m 18ft 4in	5.60m 18ft 4in	5.60m 18ft 4in
Max. Platform Height (Outdoor) ANSI92.20	4.60m 15ft 1in	4.60m 15ft 1in	4.60m 15ft 1in	4.60m 15ft 1in
Overall Length(Without Ladder)	1.37m 4ft 6in	/	/	/
Overall Length(With Ladder) C	1.52m 5ft	1.54m 5ft 1in	1.52m 5ft	1.54m 5ft 1in
Overall Width D	0.81m 2ft 8in	0.81m 2ft 8in	0.81m 2ft 8in	0.81m 2ft 8in
Overall Height(Rails Up) E	2.01m 6ft 7in	2.08m 6ft 10in	2.01m 6ft 7in	2.09m 6ft 10in
Overall Height(Rails Down) F	1.65m 5ft 5in	1.72m 5ft 8in	1.65m 5ft 5in	1.73m 5ft 8in
Platform Size(L×W)	1.37m×0.70m 4ft 6in×2ft 4in	1.37m×0.70m 4ft 6in×2ft 4in	1.37m×0.70m 4ft 6in×2ft 4in	1.37m×0.70m 4ft 6in×2ft 4in
Platform Extension Size G	0.60m 2ft	0.60m 2ft	0.60m 2ft	0.60m 2ft
Ground Clearance(Stowed/Raised)	0.06m/0.015m 2in/1in	0.07m/0.015m 3in/1in	0.06m/0.015m 2in/1in	0.07m/0.015m 3in/1in
Wheelbase H	1.13m 3ft 8in	1.15m 3ft 9in	1.13m 3ft 8in	1.15m 3ft 9in
Turning Radius(Inside/Outside)	0.45m/1.60m 1ft 6in/5ft 3in	0.45m/1.60m 1ft 6in/5ft 3in	0.45m/1.60m 1ft 6in/5ft 3in	0.45m/1.60m 1ft 6in/5ft 3in
Tyres	Φ230×100mm	Φ305×100mm	Φ230×100mm	Φ305×100mm
Performance				
S.W.L	230kg 507lb	230kg 507lb	230kg 507lb	230kg 507lb
S.W.L On Extension	113kg 249lb	113kg 249lb	113kg 249lb	113kg 249lb
Max. Occupants (Indoor/Outdoor) CE	2/0	2/0	2/0	2/0
Max. Occupants (Indoor/Outdoor) ANSI92.20	2/1	/	/	/
Gradeability	25%	25%	25%	25%
Travel Speed(Stowed)	4.0km/h 2.49mph	4.0km/h 2.49mph	4.0km/h 2.49mph	4.0km/h 2.49mph
Travel Speed(Raised)	0.6km/h 0.37mph	0.6km/h 0.37mph	0.6km/h 0.37mph	0.6km/h 0.37mph
Max. Working Slope	1.5°/3°	1.5°/3°	1.5°/3°	1.5°/3°
Up/Down Speed	30/23sec	30/23sec	24/24sec	24/24sec
Weight				
Overall Weight(Lead-acid Battery)	1300kg 2866lb	1300kg 2866lb	1340kg 2954lb	1340kg 2954lb
Power				
Hydraulic Tank	4L 1gal	4L 1gal	/	/
Battery(Lead-acid Battery)	24V/115AH	24V/115AH	24V/115AH	24V/115AH
Charger	24V/15A	24V/15A	24V/15A	24V/15A
Driving Motor	2×24VDC/0.5kW	2×24VDC/0.45kW	2×24VDC/0.7kW	2×24VDC/0.7kW
Lifting Motor	24VDC/2.2kW	24VDC/2.2kW	24VDC/1.8kW	24VDC/1.8kW

Electric

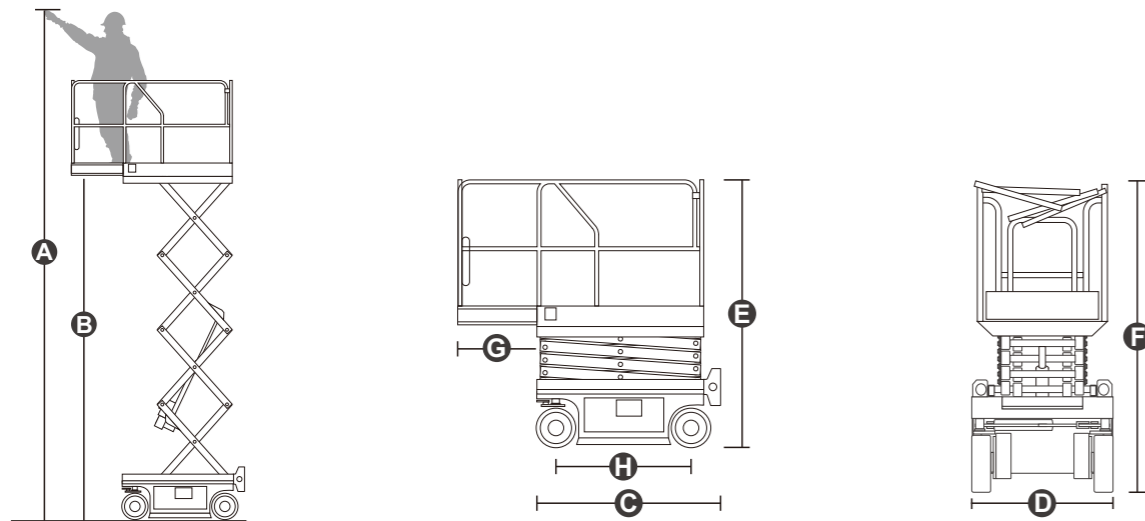

Model		JCPT0707DCM
Dimension		
Max. Working Height (Indoor) CE,ANSI92.20 A	6.50m 21ft 4in	
Max. Working Height (Outdoor) ANSI92.20 B	6.50m 21ft 4in	
Max. Platform Height (Indoor) CE,ANSI92.20	4.50m 14ft 9in	
Max. Platform Height (Outdoor) ANSI92.20	4.50m 14ft 9in	
Overall Length(Without Ladder)	1.43m 4ft 8in	
Overall Length(With Ladder) C	1.58m 5ft 2in	
Overall Width D	0.76m 2ft 6in	
Overall Height(Rails Up) E	2.05m 6ft 9in	
Overall Height(Rails Down) F	1.68m 5ft 6in	
Platform Size(L×W)	1.44m×0.74m 4ft 9in×2ft 5in	
Platform Extension Size G	0.60m 2ft	
Ground Clearance(Stowed/Raised)	0.07m/0.016m 3in/1in	
Wheelbase H	1.12m 3ft 8in	
Turning Radius(Inside/Outside)	0m/1.30m 0m/4ft 3in	
Tyres	Φ305×100mm	
Performance		
S.W.L	230kg 507lb	
S.W.L On Extension	113kg 249lb	
Max. Occupants (Indoor/Outdoor) CE	2/1	
Max. Occupants (Indoor/Outdoor) ANSI92.20	/	
Gradeability	25%	
Travel Speed(Stowed)	4.5km/h 2.80mph	
Travel Speed(Raised)	0.6km/h 0.37mph	
Max. Working Slope	1.5°/3°	
Up/Down Speed	22/20sec	
Weight		
Overall Weight(Lead-acid Battery)	1200kg 2646lb	
Power		
Hydraulic Tank	3.5L 0.9gal	
Battery(Lead-acid Battery)	24V/115AH	
Charger	24V/15A	
Driving Motor	2×24VDC/0.5kW	

Electric

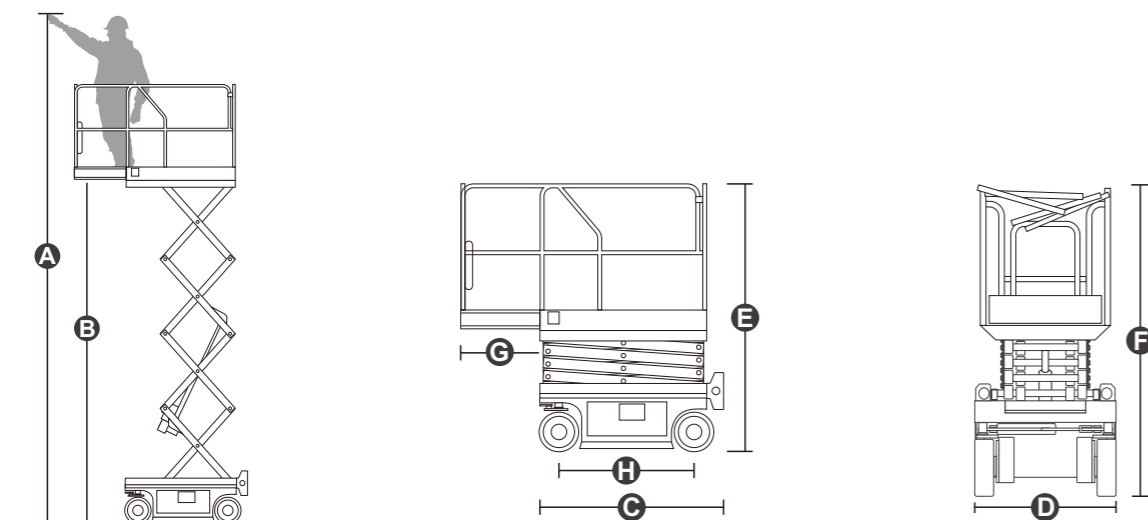

Model		JCPT0608DCH
Dimension		
Max. Working Height (Indoor) CE,ANSI92.20 A	6.50m 21ft 4in	
Max. Working Height (Outdoor) ANSI92.20 B	5.50m 18ft	
Max. Platform Height (Indoor) CE,ANSI92.20	4.50m 14ft 9in	
Max. Platform Height (Outdoor) ANSI92.20	3.50m 11ft 6in	
Overall Length C	1.54m 5ft 1in	
Overall Width D	0.81m 2ft 8in	
Overall Height(Rails Up) E	2.00m 6ft 7in	
Overall Height(Rails Down) F	1.64m 5ft 5in	
Platform Size(L×W)	1.37m×0.70m 4ft 6in×2ft 3in	
Platform Extension Size G	0.60m 2ft	
Ground Clearance(Stowed/Raised)	0.07m/0.015m 3in/1in	
Wheelbase H	1.15m 3ft 9in	
Turning Radius(Inside/Outside)	0.45m/1.60m 1ft 6in/5ft 3in	
Tyres	Φ305×100mm	
Performance		
S.W.L	230kg 507lb	
S.W.L On Extension	113kg 249lb	
Max. Occupants (Indoor/Outdoor) CE	2/0	
Max. Occupants (Indoor/Outdoor) ANSI92.20	/	
Gradeability	25%	
Travel Speed(Stowed)	4.0km/h 2.48mph	
Travel Speed(Raised)	0.6km/h 0.37mph	
Max. Working Slope	1.5°/3°	
Up/Down Speed	21/19sec	
Weight		
Overall Weight(Lead-acid Battery)	995kg 2193lb	
Power		
Hydraulic Tank	4L 1gal	
Battery(Lead-acid Battery)	24V/115AH	
Charger	24V/15A	
Driving Motor	2×24VDC/0.45kW	
Lifting Motor	24VDC/2.2kW	

Electric

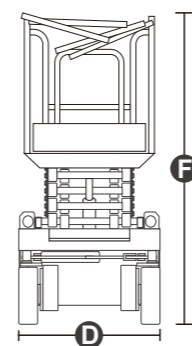
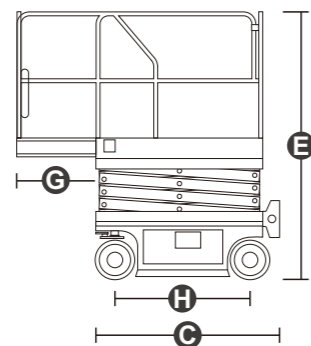
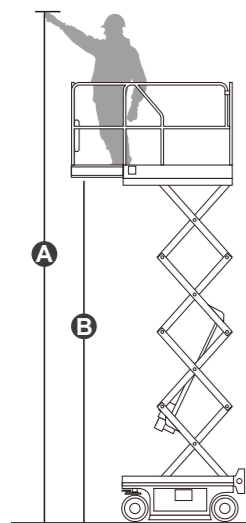

Model	JCPT0607DCM	JCPT0607DCH
Dimension		
Max. Working Height (Indoor) CE,ANSI92.20 A	5.60m 18ft 4in	5.60m 18ft 4in
Max. Working Height (Outdoor) ANSI92.20 B	5.60m 18ft 4in	5.60m 18ft 4in
Max. Platform Height (Indoor) CE,ANSI92.20	3.60m 11ft 10in	3.60m 11ft 10in
Max. Platform Height (Outdoor) ANSI92.20	3.60m 11ft 10in	3.60m 11ft 10in
Overall Length(Without Ladder)	1.29m 4ft 3in	/
Overall Length(With Ladder) C	1.44m 4ft 9in	1.46m 4ft 9in
Overall Width D	0.76m 2ft 6in	0.76m 2ft 6in
Overall Height(Rails Up) E	1.99m 6ft 6in	2.06m 6ft 9in
Overall Height(Rails Down) F	1.62m 5ft 3in	1.69m 5ft 7in
Platform Size(L×W)	1.29m×0.70m 4ft 3in×2ft 4in	1.29m×0.70m 4ft 3in×2ft 4in
Platform Extension Size G	0.60m 2ft	0.60m 2ft
Ground Clearance(Stowed/Raised)	0.06m/0.015m 2in/1in	0.07m/0.015m 3in/1in
Wheelbase H	1.05m 3ft 5in	1.06m 3ft 6in
Turning Radius(Inside/Outside)	0.40m/1.55m 1ft 4in/5ft 1in	0.40m/1.55m 1ft 4in/5ft 1in
Tyres	Φ230×80mm	Φ305×100mm
Performance		
S.W.L	240kg 529lb	240kg 529lb
S.W.L On Extension	100kg 220lb	100kg 220lb
Max. Occupants (Indoor/Outdoor) CE	2/1	2/1
Max. Occupants (Indoor/Outdoor) ANSI92.20	/	/
Gradeability	25%	25%
Travel Speed(Stowed)	4.0km/h 2.49mph	4.0km/h 2.49mph
Travel Speed(Raised)	0.6km/h 0.37mph	0.6km/h 0.37mph
Max. Working Slope	1.5°/3°	1.5°/3°
Up/Down Speed	27/20sec	27/20sec
Weight		
Overall Weight(Lead-acid Battery)	920kg 2028lb	960kg 2116lb
Power		
Hydraulic Tank	3L 0.8gal	3L 0.8gal
Battery(Lead-acid Battery)	24V/85AH	24V/85AH
Charger	24V/15A	24V/15A
Driving Motor	2×24VDC/0.4kW	2×24VDC/0.45kW
Lifting Motor	24VDC/1.2kW	24VDC/1.2kW

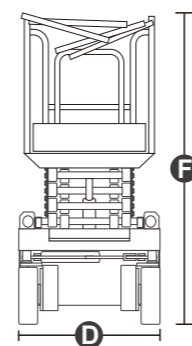
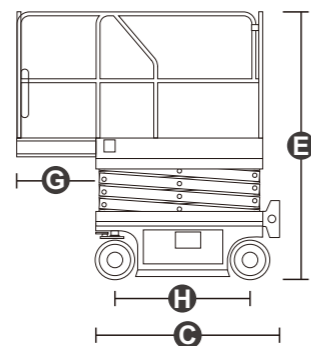
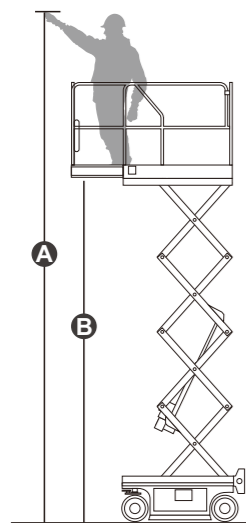

Model	JCPT0607PA	JCPT0607PAH
Dimension		
Max. Working Height (Indoor) CE,ANSI92.20 A	5.60m 18ft 4in	5.60m 18ft 4in
Max. Working Height (Outdoor) ANSI92.20 B	5.60m 18ft 4in	5.60m 18ft 4in
Max. Platform Height (Indoor) CE,ANSI92.20	3.60m 11ft 10in	3.60m 11ft 10in
Max. Platform Height (Outdoor) ANSI92.20	3.60m 11ft 10in	3.60m 11ft 10in
Overall Length(Without Ladder)	/	/
Overall Length(With Ladder) C	1.44m 4ft 9in	1.46m 4ft 9in
Overall Width D	0.76m 2ft 6in	0.76m 2ft 6in
Overall Height(Rails Up) E	1.99m 6ft 6in	2.06m 6ft 9in
Overall Height(Rails Down) F	1.62m 5ft 4in	1.69m 5ft 6in
Platform Size(L×W)	1.29m×0.70m 4ft 3in×2ft 4in	1.29m×0.70m 4ft 3in×2ft 4in
Platform Extension Size G	0.60m 2ft	0.60m 2ft
Ground Clearance(Stowed/Raised)	0.06m/0.015m 2in/1in	0.07m/0.015m 3in/1in
Wheelbase H	1.05m 3ft 5in	1.06m 3ft 6in
Turning Radius(Inside/Outside)	0.40m/1.55m 1ft 4in/5ft 1in	0.40m/1.55m 1ft 4in/5ft 1in
Tyres	Φ230×80mm	Φ305×100mm
Performance		
S.W.L	240kg 529lb	240kg 529lb
S.W.L On Extension	100kg 220lb	100kg 220lb
Max. Occupants (Indoor/Outdoor) CE	2/1	2/1
Max. Occupants (Indoor/Outdoor) ANSI92.20	/	/
Gradeability	25%	25%
Travel Speed(Stowed)	4.0km/h 2.48mph	4.0km/h 2.48mph
Travel Speed(Raised)	0.6km/h 0.37mph	0.6km/h 0.37mph
Max. Working Slope	1.5°/3°	1.5°/3°
Up/Down Speed	22/22sec	22/22sec
Weight		
Overall Weight(Lead-acid Battery)	920kg 3018lb	950kg 3116lb
Power		
Hydraulic Tank	/	/
Battery(Lead-acid Battery)	24V/85AH	24V/85AH
Charger	24V/15A	24V/15A
Driving Motor	2×24VDC/0.7kW	2×24VDC/0.7kW
Lifting Motor	24VDC/1.4kW	24VDC/1.4kW

Electric

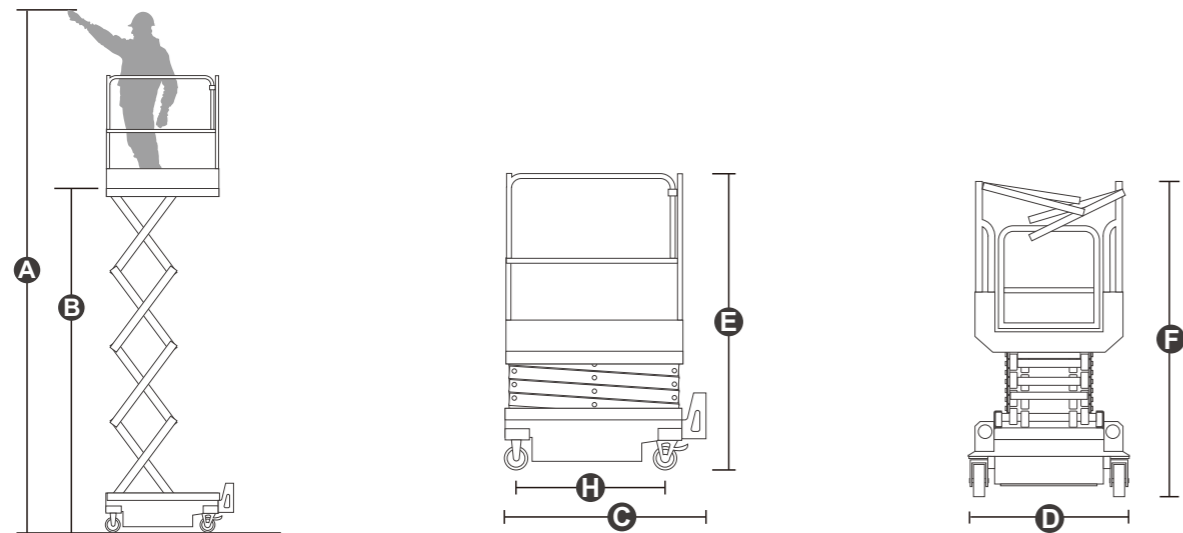

Model		JCPT0607B
Dimension		
Max. Working Height (Indoor) CE,ANSI92.20 A	5.90m 19ft 4in	
Max. Working Height (Outdoor) ANSI92.20 B	5.90m 19ft 4in	
Max. Platform Height (Indoor) CE,ANSI92.20	3.90m 12ft 10in	
Max. Platform Height (Outdoor) ANSI92.20	3.90m 12ft 10in	
Overall Length C	1.30m 4ft 3in	
Overall Width D	0.76m 2ft 6in	
Overall Height(Rails Up) E	1.92m 6ft 4in	
Overall Height(Rails Down) F	1.52m 5ft	
Platform Size(L×W)	1.15m×0.70m 3ft 9in×2ft 4in	
Ground Clearance(Stowed/Raised)	0.06m 2in	
Wheelbase H	1.01m 3ft 4in	
Tyres	Φ150×50mm	
Performance		
S.W.L	240kg 529lb	
Max. Occupants (Indoor/Outdoor) CE	1/0	
Max. Occupants (Indoor/Outdoor) ANSI92.20	/	
Max. Working Slope	1°	
Up/Down Speed	23/21sec	
Weight		
Overall Weight(Lead-acid Battery)	480kg 1058lb	
Power		
Hydraulic Tank	3L 0.8gal	
Battery(Lead-acid Battery)	12V/85AH	
Charger	12V/15A	
Lifting Motor	12VDC/0.8kW	

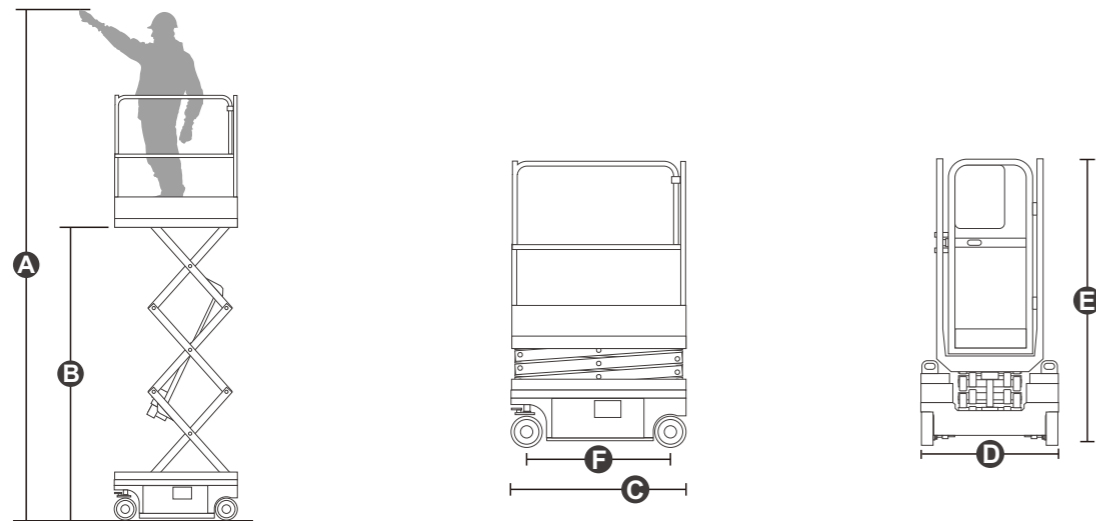

Model		JCPT0507PA
Dimension		
Max. Working Height (Indoor) CE,ANSI92.20 A		5.05m 16ft 7in
Max. Working Height (Outdoor) ANSI92.20 B		4.30m 14ft 1in
Max. Platform Height (Indoor) CE,ANSI92.20		3.05m 10ft
Max. Platform Height (Outdoor) ANSI92.20		2.30m 7ft 6in
Overall Length C		1.18m 3ft 10in
Overall Width D		0.77m 2ft 6in
Overall Height E		1.60m 5ft 3in
Platform Size(L×W)		1.16m×0.565m 3ft 10in×1ft 10in
Ground Clearance(Stowed/Raised)		0.06m/0.016m 2in×1in
Wheelbase F		0.95m 3ft 1in
Turning Radius(Inside/Outside)		0.45m/1.20m 1ft 6in/3ft 11in
Tyres		Φ200×80mm
Performance		
S.W.L		230kg 507lb
Max. Occupants (Indoor/Outdoor) CE		1
Max. Occupants (Indoor/Outdoor) ANSI92.20		/
Gradeability		25%
Travel Speed(Stowed)		4.0km/h 2.48mph
Travel Speed(Raised)		0.4km/h 0.24mph
Max. Working Slope		1.5°/3°
Up/Down Speed		20/20sec
Weight		
Overall Weight(Lead-acid Battery)		570kg 1117lb
Overall Weight(Lithium Battery)		540kg 1190lb
Power		
Battery(Lead-acid Battery)		24V/55AH
Battery(Lithium Battery)		24V/63Ah
Charger		24V/15A
Driving Motor		2×24VDC/0.6kW
Lifting Motor		24VDC/1.4kW